



brother

Quick Reference Guide

Hurtigguide

Snabbstartsguide

Quickguide

Pikaopas

Stručná referenční příručka

Gyors útmutató

Skrócona instrukcja obsługi

Ghid de referință rapidă

İsa pamācība

Be sure to read this document before using the machine.
We recommend that you keep this document nearby for future reference.

Sørg for å lese dette dokumentet før du bruker maskinen.
Vi anbefaler at du oppbevarer dette dokumentet i nærheten for fremtidig referanse.

Läs det här dokumentet innan du använder maskinen.
Vi rekommenderar att du sparar dokumentet för framtida referens.

Sørg for at læse dette dokument, inden du bruger maskinen.
Vi anbefaler, at du gemmer dette dokument, så det er ved hånden til fremtidig brug.

Muista lukea tämä dokumentti ennen koneen käyttöä.
Suosittelemme tämän dokumentin säilyttämistä koneen läheisyydessä myöhempää käyttöä varten.

Před použitím stroje si přečtěte tento dokument.
Doporučujeme tento dokument uchovávat v blízkosti stroje, aby byl k dispozici k nahlédnutí.

A gép használatba vétele előtt feltétlenül olvassa el ezt a dokumentumot.
Javasoljuk, hogy tartsa ezt a dokumentumot a gép közelében, hogy szükség esetén kéznél legyen.

Przed przystąpieniem do używania maszyny zapoznaj się z niniejszym dokumentem.
Zalecamy zachowanie tego dokumentu na przyszłość i przechowywanie go w dostępnym miejscu.

Citiți acest document înainte de a utiliza mașina.
Vă recomandăm să păstrați acest document la îndemână pentru consultare ulterioară.

Iekams lietot šujmašīnu, noteikti izlasiet šo rokasgrāmatu.
Iesakām turēt šo rokasgrāmatu pa rokai turpmākām uzziņām.

Before using your machine for the first time please read the “IMPORTANT SAFETY INSTRUCTIONS” in the Operation Manual.

Refer to the Operation Manual for detailed instructions.

In this guide, English screens are used for basic explanations.

For details on the built-in embroidery patterns, refer to the Embroidery Design Guide.

Før du bruker maskinen første gang må du lese “VIKTIGE SIKKERHETSINSTRUKSJONER” i bruksanvisningen.

Du finner detaljerte instruksjoner i bruksanvisningen.

I denne veiledningen brukes engelske skjermbilder for grunnleggende forklaringer.

Detaljer om innebygde broderimønstre finner du i motivveiledningen for brodering.

Innan du använder maskinen första gången bör du läsa avsnittet “VIKTIGA SÄKERHETSANVISNINGAR” i bruksanvisningen.

Se bruksanvisningen för utförliga instruktioner.

I denna guide används skärmbilder på engelska för grundläggande förklaringar.

För information om inbyggda broderimönster, se Guide till broderimönster.

Læs “VIGTIGE SIKKERHEDSOPLYSNINGER” i brugsanvisningen, før du tager maskinen i brug.

Se brugsanvisningen for at få detaljerede instruktioner.

Der anvendes displaybilleder på engelsk til basale forklaringer i denne vejledning.

Yderligere oplysninger om indbyggede broderimønstre kan fås i broderidesignvejledningen.

Lue käyttöohjeen kohta “TÄRKEITÄ TURVAOHJEITA” ennen kuin käytät konetta ensimmäisen kerran.

Yksityiskohtaisempia ohjeita löytyy koneen käyttöohjeesta.

Tässä oppaassa olevat näytön kuvat ovat englanninkielisen näytön mukaisia.

Lisätietoja koneen sisäänrakennetuista kirjontakuvioista on Brodeerauskuvioiden oppaassa.

Před prvním použitím stroje si prosím přečtěte „DŮLEŽITÉ BEZPEČNOSTNÍ POKYNY“ obsažené v uživatelské příručce.

Podrobné pokyny naleznete v uživatelské příručce.

V této příručce jsou za účelem základních vysvětlení použity obrazovky v angličtině.

Podrobné informace o vestavěných vyšívacích vzorech naleznete v příručce k navrhování výšivek.

A készülék első alkalommal történő használatá elött, kérjük, olvassa el a Használati útmutató „FONTOS BIZTONSÁGI UTASÍTÁSOK” c. részén foglaltakat.

A részletes utasítókét tekintse meg a Használati útmutató.

Ez az útmutató az alapvető magyarázatokat angol képernyőábrák szemléteti.

Az integrát hízémintákál kapcsolatlanban használja referenciakét a Hízéminta-útmúató.

Przed rozpoczęciem pracy z maszyną przeczytaj „WAŻNE INSTRUKCJE DOTYCZĄCE BEZPIECZEŃSTWA” w Instrukcji obsługi.

Szczegółowe informacje można znaleźć w instrukcji obsługi.

W niniejszej instrukcji podstawowe elementy są ilustrowane ekranami w języku angielskim.

Szczegółowe informacje na temat wbudowanych wzorów haftów zamieszczono w Przewodniku projektowania haftów.

Înainte de a utiliza maşina pentru prima oară, citiţi „INSTRUCŢIUNILE IMPORTANTE DE SIGURANŢĂ” din Manualul de utilizare.

Consultaţi manualul de utilizare pentru instrucţiuni detaliate.

În acest ghid, sunt utilizate ecrane în limba engleză pentru explicaţii de bază.

Pentru detalii despre modelele de broderii incluse, consultaţi Catalogul cu modele de broderii.

Pirms pirmās šujmašīnas lietošanas reizes izlasiet lietošanas instrukcijas sadaļu “SVARĪGAS DROŠĪBAS NORĀDES”.

Sīkākas norādes meklējiet lietošanas instrukcijā.

Šajā pamācībā pamata paskaidrojums tiek izmantoti ekrāna attēli angļu valodā.

Vairāk informācijas par integrētajiem izšūšanas šabloniem meklējiet sadaļā “Izšūšanas dizaina pamācība”.

Contents

Wireless Network Connection Functions	3
◆ Operations available with a wireless network connection...	3
◆ Wireless network connection.....	4
Winding/Installing the Bobbin	7
Upper Threading	9
Selecting and Sewing Stitches	11
◆ Utility Stitches.....	11
◆ Decorative Stitches.....	12
◆ Character stitches.....	12
Summary of Stitch Patterns	13
◆ Utility Stitches.....	13
◆ Decorative Stitches.....	14
◆ Character stitches.....	15
Preparing to Embroider	21
Selecting Embroidery Patterns	23

Innhold

FuFunkFunksjoner som bruker trådløs nettverkstilkobling ...	3
◆ Handlinger tilgjengelig med en trådløs nettverksforbindelse ...	3
◆ Trådløs nettverksforbindelse.....	4
Spole undertråd/plassere undertrådsspølen	7
Treing av overtråd	9
Velge og sy sting	11
◆ Nyttøsøm.....	11
◆ Prydsøm.....	12
◆ Tegnsøm.....	12
Sammendrag av sømmønstre	13
◆ Nyttøsøm.....	13
◆ Prydsøm.....	14
◆ Tegnsøm.....	15
Gjøre seg klar til å brodere	21
Velge broderimønstre	23

Innehall

Funktioner vid anslutning till trådlöst nätverk	3
◆ Åtgärder som är tillgängliga med en trådlös nätverksanslutning...	3
◆ Anslutning till trådlöst nätverk	4
Linda/sätta i spolen	7
Trå övertråden	9
Välja och sy stygn	11
◆ Nyttosömmar	11
◆ Dekorativa sömmar	12
◆ Monogramsömmar	12
Översikt över sömmar	13
◆ Nyttosömmar	13
◆ Dekorativa sömmar	14
◆ Monogramsömmar	15
Förbereda brodering	21
Välja broderimönster	23

Sisällysluettelo

Langattoman verkkoyhteyden toiminnot	3
◆ Toiminnot, jotka ovat käytettävissä langattomalla verkkoyhteydellä...	3
◆ Langaton verkkoyhteyks	4
Puolaus/Puolan asettaminen paikoilleen	7
Ylälangan langoitus	9
Ompeleiden valinta ja ompelu	11
◆ Hyötyompeleet	11
◆ Koristeompeleet.....	12
◆ Kirjainmerkkiompeleet	12
Yhteenveto ompeleista	13
◆ Hyötyompeleet	13
◆ Koristeompeleet.....	14
◆ Kirjainmerkkiompeleet	15
Kirjontaan valmistautuminen	21
Kirjontakuvioiden valinta	23

Tartalomjegyzék

Vezeték nélküli hálózati csatlakozási funkciók	3
◆ Vezeték nélküli hálózati kapcsolattal elérhető műveletek ...	3
◆ Vezeték nélküli hálózati kapcsolat.....	4
Az alsó orsó csévélése / behelyezése	7
Felsőszál befűzése	9
Öltések kiválasztása és varrás	11
◆ Haszonöltések	11
◆ Díszítőöltések	12
◆ Karakteröltések	12
Az öltésminták összefoglalása	13
◆ Haszonöltések	13
◆ Díszítőöltések	14
◆ Karakteröltések	15
Előkészítés a hímzéshez	21
Hímzésminták kiválasztása	23

Cuprins

Funcțiile conexiunii la rețeaua fără fir	3
◆ Operațiile disponibile cu o conexiune la rețeaua fără fir...	3
◆ Conexiunea la rețeaua fără fir	4
Bobinarea/Instalarea bobinei	7
Înfilarea firului superior	9
Selectarea și coaserea cusăturilor	11
◆ Cusături utilitare	11
◆ Cusături decorative.....	12
◆ Cusături caractere.....	12
Modele de cusături	13
◆ Cusături utilitare	13
◆ Cusături decorative.....	14
◆ Cusături caractere.....	15
Pregătirea pentru brodere	21
Selectarea modelelor de broderie	23

Indholdsfortegnelse

Funktioner med trådløs netværksforbindelse	3
◆ Handlinger, der kan bruges med en trådløs netværksforbindelse ...	3
◆ Trådløs netværksforbindelse.....	4
Vinding/montering af spolen	7
Trådning af overtråd	9
Valg og syning af sømme	11
◆ Nyttēsømme	11
◆ Pyntēsømme	12
◆ Alfabet.....	12
Søm oversigt	13
◆ Nyttēsømme	13
◆ Pyntēsømme	14
◆ Alfabet.....	15
Forberedelse til brodering	21
Valg af broderimønstre	23

Obsah

Funkce připojení k bezdrátové síti	3
◆ Operace dostupné s připojením k bezdrátové síti	3
◆ Připojení k bezdrátové síti	4
Navíjení/Instalace cívky	7
Zavedení horní niti	9
Volba a šití stehů	11
◆ Užítkové stehy	11
◆ Dekorativní stehy.....	12
◆ Znakové stehy	12
Souhrn vzorů stehů	13
◆ Užítkové stehy	13
◆ Dekorativní stehy.....	14
◆ Znakové stehy	15
Příprava k vyšívání	21
Volba vyšívacích vzorů	23

Spis treści

Funkcje bezprzewodowego połączenia sieciowego ...	3
◆ Funkcje dostępne przy bezprzewodowym połączeniu sieciowym ...	3
◆ Połączenie z siecią bezprzewodową.....	4
Nawijanie nici / zakładanie szpulki dolnej	7
Nawlekanie górnej nici	9
Wybieranie i wykonywanie ściegów	11
◆ Ściegi użytkowe	11
◆ Ściegi dekoracyjne.....	12
◆ Ściegi literowe	12
Podsumowanie wzorów ściegów	13
◆ Ściegi użytkowe	13
◆ Ściegi dekoracyjne.....	14
◆ Ściegi literowe	15
Przygotowanie do haftowania	21
Wybór wzorów haftu	23

Saturs

Bezvadu interneta savienojuma funkcijas	3
◆ Darbības, kurām nepieciešams bezvadu interneta savienojums...	3
◆ Bezvadu interneta savienojums.....	4
Spolītes uztišana/uzlikšana	7
Augšējais diegs	9
Dūrienu atlasīšana un šūšana	11
◆ Pamatdūrieni	11
◆ Dekoratīvie dūrieni.....	12
◆ Īpašie dūrieni.....	12
Kopsavilkums par dūrienu šabloniem	13
◆ Pamatdūrieni	13
◆ Dekoratīvie dūrieni.....	14
◆ Īpašie dūrieni.....	15
Sagatavošanās izšūšanai	21
Izšūšanas šablonu atlasīšana	23



Wireless Network Connection Functions

FuFunkFunksjoner som bruker trådløs nettverkstilkobling

Funktioner vid anslutning till trådlöst nätverk

Funktioner med trådløs netværksforbindelse

Langattoman verkkoyhteyden toiminnot

Funkce připojení k bezdrátové síti

Vezeték nélküli hálózati csatlakozási funkciók

Funkcje bezprzewodowego połączenia sieciowego

Funcțiile conexiunii la rețeaua fără fir

Bezvodu interneta savienojuma funkcijas

- ◆ Operations available with a wireless network connection
- ◆ Åtgärder som är tillgängliga med en trådlös nätverksanslutning
- ◆ Toiminnot, jotka ovat käytettävissä langattomalla verkkoyhteydellä
- ◆ Vezeték nélküli hálózati kapcsolattal elérhető műveletek
- ◆ Operațiile disponibile cu o conexiune la rețeaua fără fir
- ◆ Handleringer tilgjengelig med en trådløs nettverksforbindelse
- ◆ Handleringer, der kan bruges med en trådløs netværksforbindelse
- ◆ Operace dostupné s připojením k bezdrátové síti
- ◆ Funkcje dostępne przy bezprzewodowym połączeniu sieciowym
- ◆ Darbības, kurām nepieciešams bezvodu interneta savienojums

	<p>Wirelessly transfer an embroidery pattern from your computer to the machine by using the dedicated Windows application (Design Database Transfer).</p> <p>Överför trådlöst ett brodermönster från datorn till maskinen genom att använda det dedikerade Windows-programmet (Design Database Transfer).</p> <p>Voit siirtää kirjontakuvion langattomasti tietokoneeltasi koneelle käyttämällä tähän tarkoitettua Windows-sovellusta (Design Database Transfer).</p> <p>Hímzés minta vezeték nélküli átvitele a számítógépről a gépre az erre a célra szolgáló Windows alkalmazással (Design Database Transfer).</p> <p>Transferați fără fir un model de broderie de pe computer pe mașină utilizând aplicația Windows dedicată (Design Database Transfer).</p>	<p>Du kan overføre et broderimønster trådløst fra datamaskinen din til maskinen ved bruk av Windows-programmet (Design Database Transfer) for dette formålet.</p> <p>Overfør et broderimønster trådløst fra din computer til maskinen ved hjælp af det dedikerede Windows-program (Design Database Transfer).</p> <p>Bezdrátově přeneste vyšivací vzor ze svého počítače do stroje pomocí speciální aplikace systému Windows (Design Database Transfer).</p> <p>Przesyłaj bezprzewodowo wzory haftu z komputera do maszyny za pomocą dedykowanej aplikacji dla systemu Windows (Design Database Transfer).</p> <p>Pārsūtiet izšūšanas šablonu no datora uz šujmašīnu ar bezvodu interneta savienojuma starpniecību, izmantojot Windows lietojumprogrammu (Design Database Transfer).</p>
	<p>Wirelessly transfer to the machine an embroidery pattern edited with embroidery editing software (PE-DESIGN version 11 or later) on a computer. Also, transfer to PE-DESIGN an embroidery pattern edited on the machine.</p> <p>Överför trådlöst ett brodermönster som redigerats med broderiredigeringsprogram (PE-DESIGN version 11 eller senare) till maskinen. Överför även ett brodermönster som redigerats på maskinen till PE-DESIGN.</p> <p>Voit siirtää tietokoneella kirjontakuvion suunnitteluohjelmalla (PE-DESIGN, versio 11 tai uudempi) suunnitellun kirjontakuvion langattomasti koneelle. Lisäksi voit siirtää PE-DESIGN-ohjelmaan koneella suunnitellun kirjontakuvion.</p> <p>Egy számítógépen lévő hímzés szerkesztő szoftverrel (PE-DESIGN 11-es vagy újabb verzió) szerkesztett hímzés minta vezeték nélküli átvitele a gépre. Továbbá a gépen szerkesztett minta átvitele a PE-DESIGN szoftverbe.</p> <p>Transferați fără fir pe mașină un model de broderie editat pe un computer cu programul de editare a broderiilor (PE-DESIGN versiunea 11 sau ulterioară). De asemenea, transferați în PE-DESIGN un model de broderie editat pe mașină.</p>	<p>Overføre trådløst et broderimønster til maskinen, som er blitt redigert med programvaren for broderiredigering (PE-DESIGN versjon 11 eller nyere) på en datamaskin. Du kan også overføre til PE-DESIGN et broderimønster som er blitt redigert på maskinen.</p> <p>Overfør et broderimønster redigeret med broderiredigeringssoftware (PE-DESIGN version 11 eller nyere) trådløst til maskinen fra en computer. Du kan også overføre et mønster redigeret på maskinen til PE-DESIGN.</p> <p>Bezdrátově přeneste do stroje vyšivací vzor upravený softwarem pro úpravu vyšivek (PE-DESIGN verze 11 nebo novější) na počítači. Rovněž přeneste do softwaru PE-DESIGN vyšivací vzor upravený na stroji.</p> <p>Przesyłaj bezprzewodowo do maszyny wzory haftu edytowane na komputerze za pomocą oprogramowania do edycji haftów (PE-DESIGN wersja 11 lub nowsza). Możesz też przysyłać do PE-DESIGN wzory haftu edytowane na maszynie.</p> <p>Nosūtiet uz šujmašīnu izšūšanas šablonu, kas datorā rediģēts ar izšūšanas rediģēšanas programmu (PE-DESIGN 11. vai jaunāku versiju). Jūs varat arī pārsūtīt šujmašīnā labotu izšūšanas šablonu, izmantojot programmu PE-DESIGN.</p>

When an updated version of software is available on our website, the wireless LAN key appears as .

Når en oppdatert versjon av programvaren er tilgjengelig på nettstedet vårt, vises nøkkelen til det trådløse LAN-nettverket som .

Kun ohjelmiston päivitetty versio on saatavilla verkkosivuiltamme, langattoman lähiverkon symboli näkyy muodossa .

Ha a szoftver frissített verziója elérhető a weboldalunkon, a vezeték nélküli LAN-kulcs -ként jelenik meg.

Dacă pe site-ul nostru web este disponibilă o versiune de actualizare a programului, pictograma rețelei LAN fără fir afișată este .

Når en oppdatert versjon av programvaren er tilgjengelig på nettstedet vårt, vises nøkkelen til det trådløse LAN-nettverket som .

Når en opdateret version af softwaren er tilgængelig på vores websted, vises nøglen til trådløst LAN som .

Když je na našich webových stránkách k dispozici aktualizovaná verze softwaru, klíč bezdrátové sítě LAN se zobrazí jako .

Gdy w naszej witrynie dostępna jest zaktualizowana wersja oprogramowania, przycisk bezprzewodowej sieci LAN zmienia wygląd na .

Ja mūsu tīmekļa vietnē tiek atjaunināta programmatūras versija, bezvadu LAN taustiņš būs redzams kā .

- ◆ Wireless network connection
- ◆ Anslutning till trådlöst nätverk
- ◆ Langaton verkkoyhteys
- ◆ Vezeték nélküli hálózati kapcsolatok
- ◆ Conexiunea la rețeaua fără fir

- ◆ Trådløs nettverksforbindelse
- ◆ Trådløs netværksforbindelse
- ◆ Připojení k bezdrátové síti
- ◆ Połączenie z siecią bezprzewodową
- ◆ Bezvadu interneta savienojums



When you first turn on the machine, the following message about a wireless LAN connection appears.

To set up a connection, touch , and then continue with step .

Når du setter på maskinen vises følgende meddelelse om ett trådløst LAN-nettverk.

För att upprätta en anslutning, tryck på  och fortsätt sedan med steg .

Kun käynnistät koneen ensimmäisen kerran, näyttöön tulee seuraava langattoma lähiverkkoyhteyttä koskeva viesti.

Muodosta yhteys valitsemalla  ja jatka sitten vaiheeseen .



A gép első bekapcsolásakor a következő üzenet jelenik meg a vezeték nélküli LAN-kapcsolatról.

A kapcsolat beállításához érintse meg a  elemet, majd folytassa a  lépéssel.

La prima pornire a mașinii, va fi afișat următorul mesaj despre o conexiune LAN fără fir.

Pentru a configura o conexiune, atingeți  și apoi continuați configurarea de la pasul .

Når du først slår på maskinen, vises følgende melding om en trådløs LAN-tilkobling.

Du setter opp en forbindelse ved å trykke på  og deretter fortsette med trinn .



Første gang du tænder maskinen vises følgende meddelelse om en trådløs LAN-forbindelse.

Tryk på , og fortsæt med trin  for at konfigurere en forbindelse.

Při prvním zapnutí stroje se zobrazí následující zpráva o připojení k bezdrátové síti LAN.

Připojení nastavíte stiskem  pak pokračujte krokem .

Po włączeniu maszyny po raz pierwszy pojawia się poniższy komunikat dotyczący połączenia z bezprzewodową siecią LAN.

Aby ustanowić połączenie, naciśnij przycisk  a następnie przejdź do punktu .

Pirmoreiz ieslēdzot šujmašīnu, tiks parādīts turpmāk minētais ziņojums par bezvadu LAN savienojumu.

Lai iestatītu savienojumu, pieskarieties  un tad turpiniet ar  darbību.

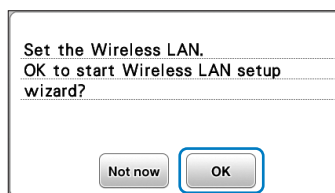

1

Find your security information (SSID and network key) and note it.

Hitta din säkerhetsinformation (SSID och nätverksnyckel) och skriv ned den.

Etsi langattoman verkon nimi ja salasana (SSID ja verkkoavain) ja merkitse ne muistiin.

Keresse meg a biztonsági adatokat (SSID és hálózati kulcs), és jegyezze fel azokat.

Găsiți informațiile de securitate (SSID și cheie de rețea) și notați-le.

Finn sikkerhetsinformasjonen din (SSID og nettverksnøkkel) og skriv den ned.

Find dine sikkerhedsoplysninger (SSID og netværksnøgle), og notér dem.

Vyhleďte své zabezpečovací informace (identifikátor SSID a síťový klíč) a zaznamenejte si je.

Odszukaj informacje o zabezpieczeniach (identyfikator SSID i klucz sieciowy) i zanotuj je.

Atrodiet informāciju par drošību (SSID un tīkla atslēga) un pierakstiet to.

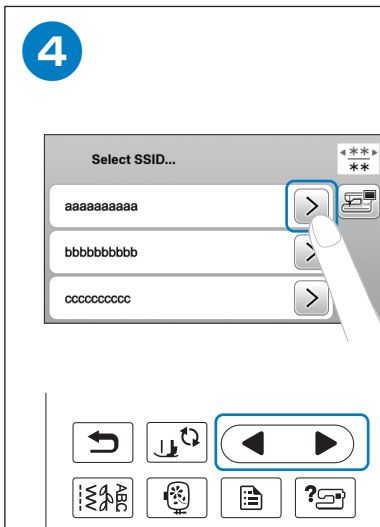
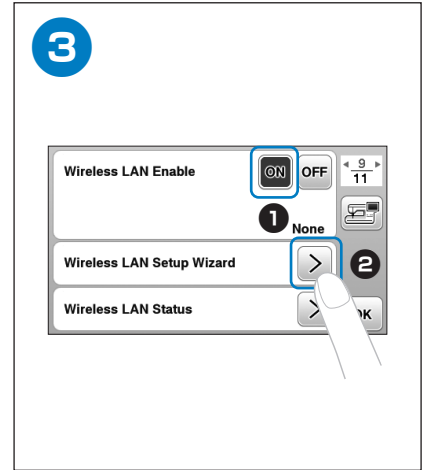
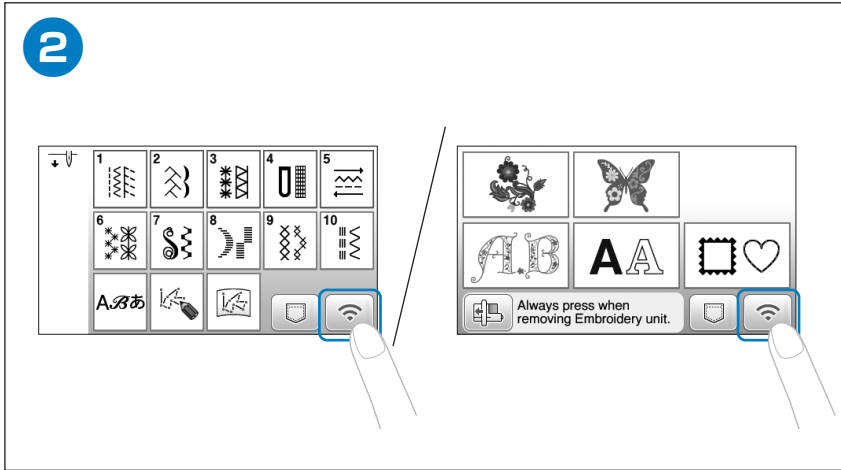

Touch **>** beside the SSID that was noted in step **1**.

- When displaying next or previous pages, touch **<** or **>** key to search the SSID that was noted.

Trykk på **>** ved siden av SSID-en som du merket deg i trinn **1**.

- Når det vises neste eller forrige sider, må du trykke på **<**- eller **>**-tasten for å søke etter SSID-en du merket deg.

Tryck på **>** bredvid det SSID som skrevs ned i steg **1**.

- Når du visar nästa eller föregående sidor trycker du på knappen **<** eller **>** för att söka efter det SSID som du skrev ned.

Tryk på **>** ved siden af den SSID, der blev noteret i trin **1**.

- Når næste eller forrige side vises, skal du trykke på ved **<** eller tasten **>** for at søge efter den SSID, der blev noteret.

Valitse **>** sen langattoman verkon nimen vierestä, joka merkittiin muistiin vaiheessa **1**.

- Jos sivuja on useita, etsi oikea verkon nimi painamalla painikkeita **<** ja **>**.

Stiskněte **>** vedle identifikátoru SSID zaznamenaného v kroku **1**.

- Po zobrazení další nebo předchozí stránky vyhledejte stisknutím **<** nebo **>** zaznamenaný identifikátor SSID.

Érintse meg az **1**. lépésben feljegyzett SSID mellett a **>** elemet.

- A következő vagy előző oldalak megjelenítésekor érintse meg a **<** vagy a **>** billentyűt a feljegyzett SSID kereséséhez.

Dotknij przycisku **>** znajdującego się obok identyfikatora SSID zanotowanego w punkcie **1**.

- Jeśli wyświetlono następnę bądź poprzednie strony, dotknij przycisku **<** albo **>**, aby wyszukać zanotowany identyfikator SSID.

Atingeți **>** aflat lângă SSID-ul notat în pasul **1**.

- Când paginile anterioare sau următoare sunt afișate, atingeți tasta **<** sau tasta **>** pentru a căuta SSID-ul notat.

Pieskarieties SSID blakus esošajam taustiņam **>**, kas tika minēts **1**. darbībā.

- Kad parādās nākamā vai iepriekšējā lapa, pieskarieties taustiņam **<** vai **>**, lai meklētu pieminēto SSID.

5

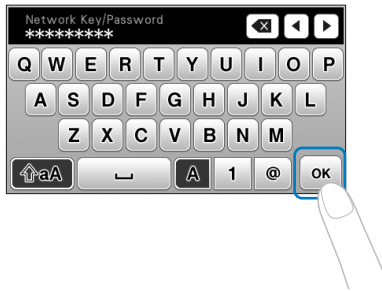

Enter the network key (password) that was noted, and then touch **OK**.

Skriv inn nettverksnøkkelen (passordet) du merket deg og trykk deretter på **OK**.

Ange nätverksnyckeln (lösenordet) som du skrivit ned och tryck sedan på **OK**.

Indtast den netværksnøgle (adgangskode), der blev noteret, og tryk derefter på ved **OK**.

Syötä muistiin merkitsemäsi salasana (verkkoavain) ja valitse **OK**.

Zadejte síťový klíč (heslo), který byl zaznamenán, a poté stiskněte **OK**.

Írja be a feljegyzett hálózati kulcsot (jelszót), majd érintse meg a **OK** gombot.

Wprowadź zanotowany klucz sieciowy (hasło), a następnie dotknij przycisku **OK**.

Introduceți cheia de rețea (parola) notată și apoi atingeți **OK**.

Ievadiet pierakstīto tīkla atslēgu (paroli) un pieskarieties **OK**.

6

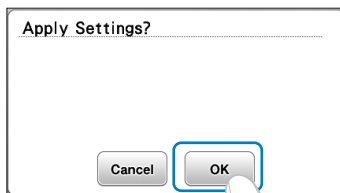

7

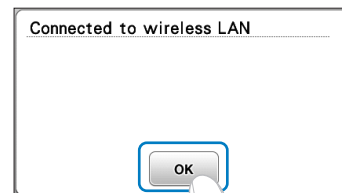

8

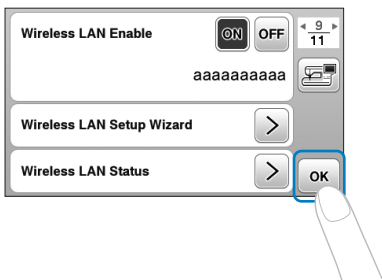

Touch **OK** to exit the setup.

Trykk på **OK** for å avslutte oppsettet.

Tryck på **OK** för att avsluta konfigureringen.

Tryk på **OK** for at afslutte konfigurationen.

Poistu määrittäksestä valitsemalla **OK**.

Stiskem **OK** ukončíte nastavení.

Érintse meg a **OK** gombot a beállításból való kilépéshez.

Dotknij przycisku **OK**, aby zakończyć konfigurację.

Atingeți **OK** pentru a ieși din configurare.

Lai izietu no iestatīšanas režīma, pieskarieties **OK**.



Winding/Installing the Bobbin

Spole undertråd/plassere undertrådsspolen

Linda/sätta i spolen

Vinding/montering af spolen

Puolaus/Puolan asettaminen paikoilleen

Navijení/Instalace cívky

Az alsó orsó csévélése / behelyezése

Nawijanie nici / zakładanie szpulki dolnej

Bobinarea/Instalarea bobinei

Spolītes uztišana/uzlikšana

Follow the steps below in numerical order. Refer to the Operation Manual for detailed instructions.
 Følg fremgangsmåten nedenfor i nummerrekkefølge. Du finner detaljerte instruksjer i bruksanvisningen.
 Følg stegen nedan, i nummerordning. Se bruksanvisningen för utförliga instruktioner.
 Følg nedenstående trin i numerisk rækkefølge. Se brugsanvisningen for at få detaljerede instruktioner.
 Noudata alla annettujen vaiheita numerijärjestyksessä. Lisätietoja on käyttöohjeessa.
 Postupujte podle níže uvedených kroků v pořadí podle čísel. Podrobné pokyny naleznete v uživatelské příručce.
 Kövesse az alábbi lépéseket számsorrendben. A részletes utasításokért tekintse meg a Használati útmutatót.
 Wykonać poniższe kroki w kolejności oznaczonej numerami. Szczegółowe informacje można znaleźć w instrukcji obsługi.
 Urmați pașii de mai jos, în ordinea indicată. Consultați manualul de utilizare pentru instrucțiuni detaliate.
 Ievērojiet zemāk norādītos soļus skaitliskā secībā. Sīkākas norādes meklējiet lietošanas instrukcijā.

Use the plastic bobbin that comes with this machine or bobbins of the same type.
 Bruk plastspolen som følger med maskinen, eller spoler av samme type som denne.
 Använd plastspolen som medföljer maskinen eller spolar av samma typ.
 Brug kun plastikspolen, der følger med denne maskine, eller spoler af samme type.
 Käytä tämän koneen mukana tullutta muovipuolaa tai muuta samantyyppisiä puolia.
 Používajte plastovú cívku, ktorá sa dodáva s tímto strojom, alebo cívky stejného typu.
 Használja a géphez mellékelte műanyag alsó orsót vagy azonos típusú alsó orsókat.
 Używaj plastikowej szpulki dolnej, która została dostarczona z maszyną lub szpulki tego samego typu.
 Utilizați bobina din plastic primită la cumpărarea acestei mașini sau bobine de același tip.
 Izmantojiet šīs šujmašīnas komplektācijā iekļauto plastmasas spoliņu vai tāda paša veida spoliņus.

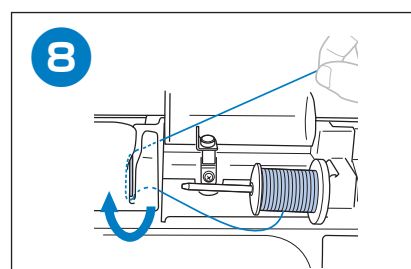
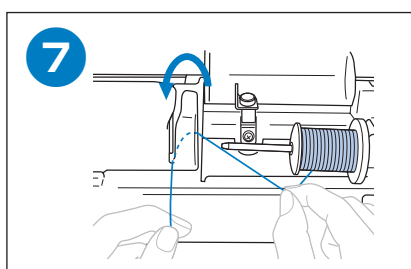
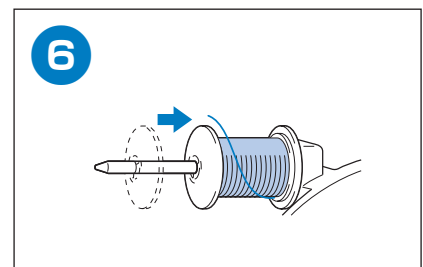
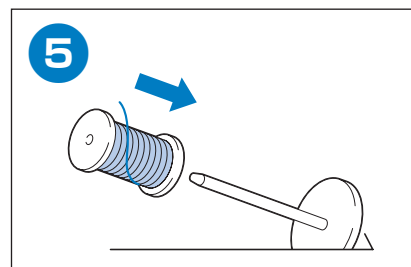
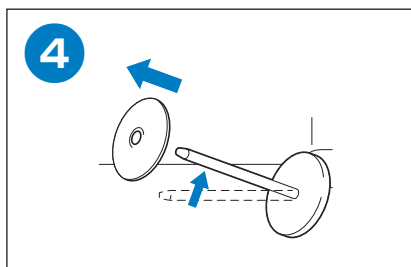
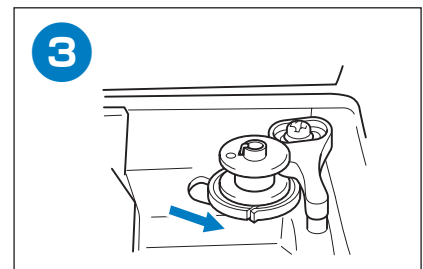
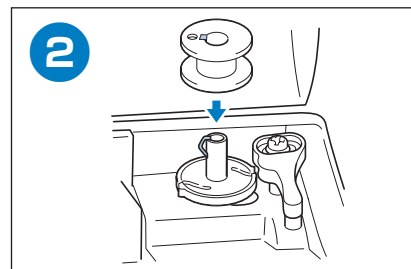
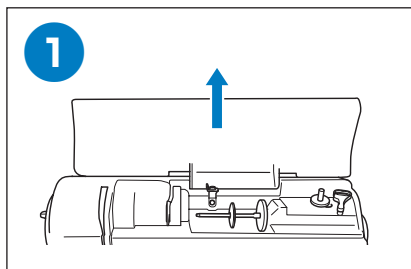
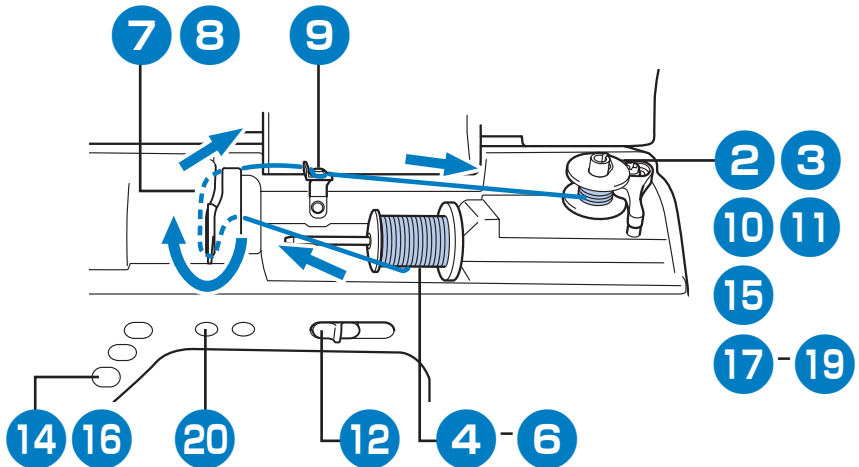
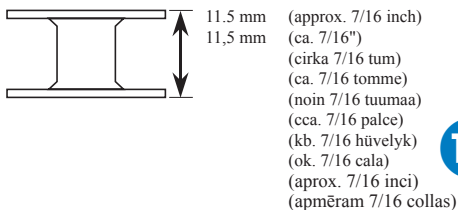

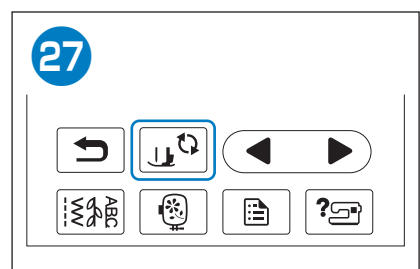
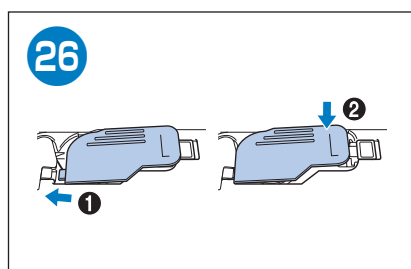
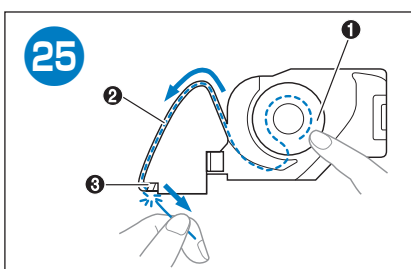
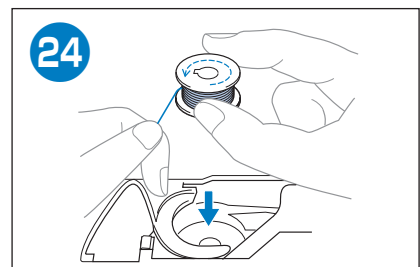
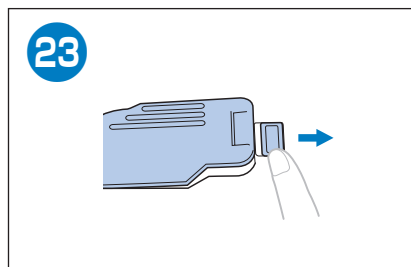
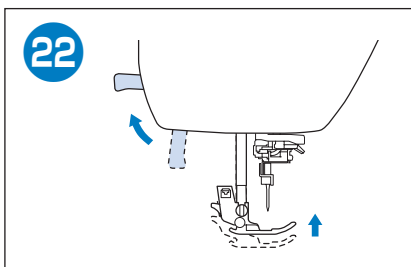
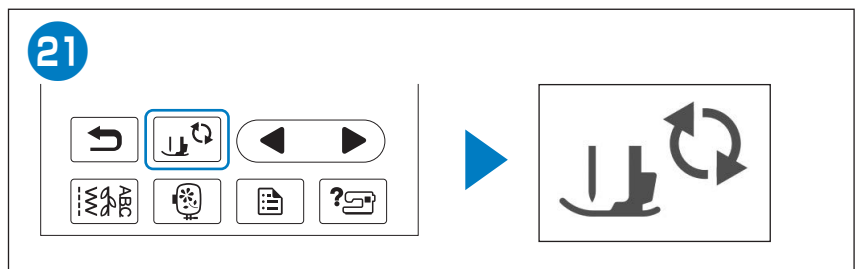
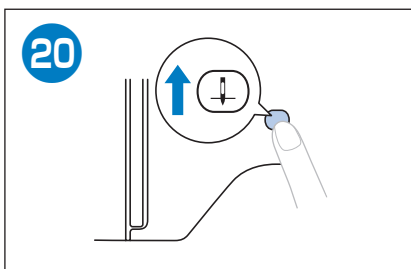
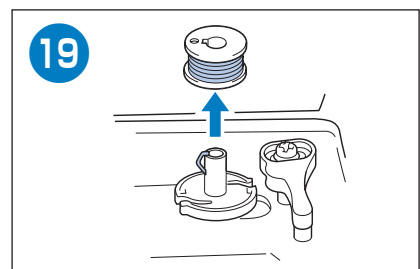
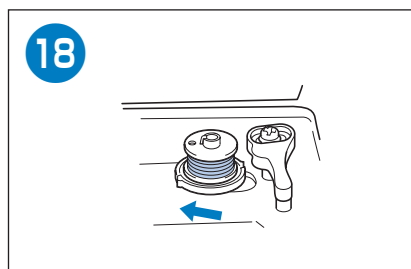
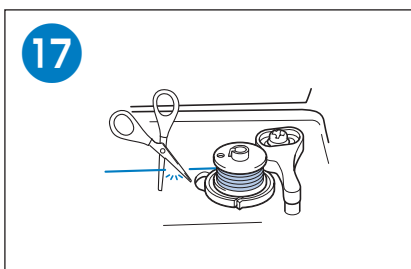
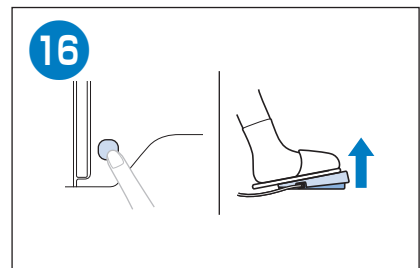
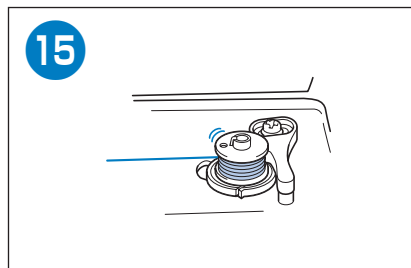
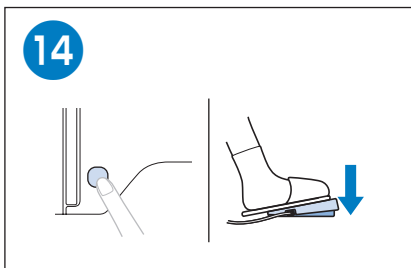
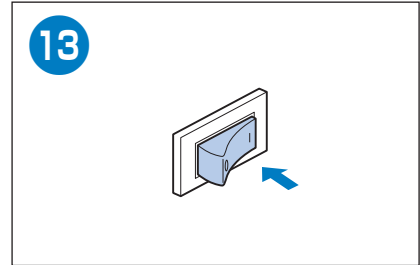
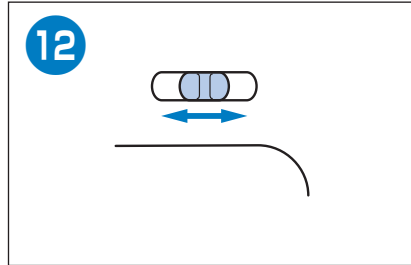
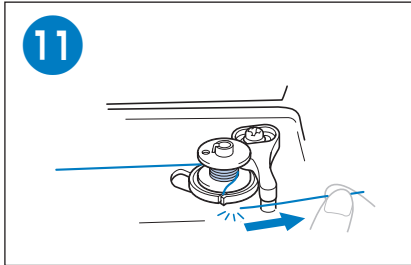
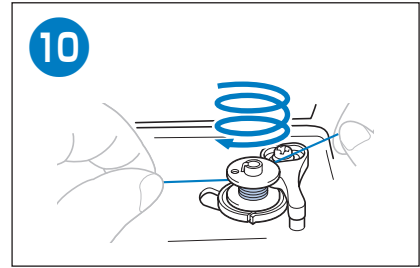
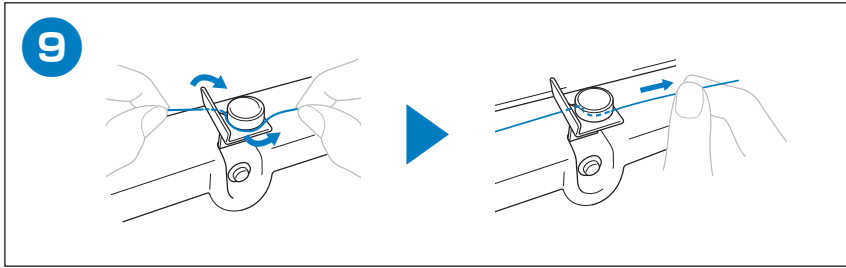

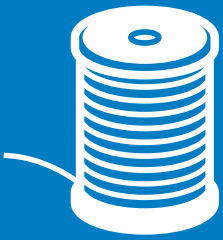

Upper Threading
Treing av övertråd
Trä övertråden
Trådning af overtråd
Ylälangan langoitus
Zavedení horní niti
Felsőszál befűzése
Nawlekanie górnej nici
Înfilarea firului superior
Augšējais diegs

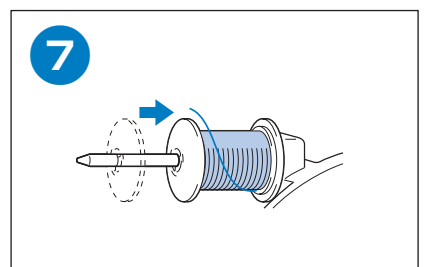
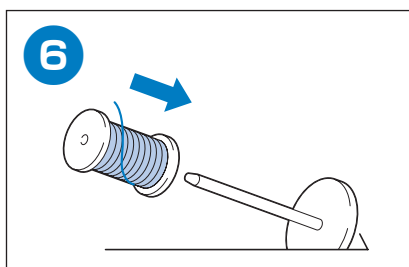
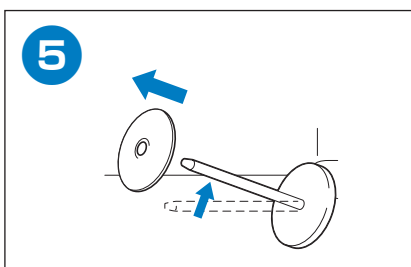
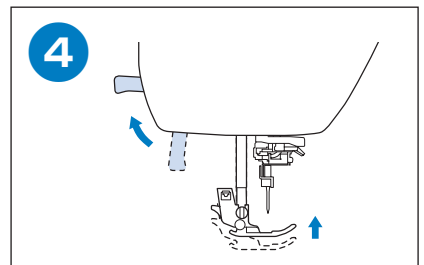
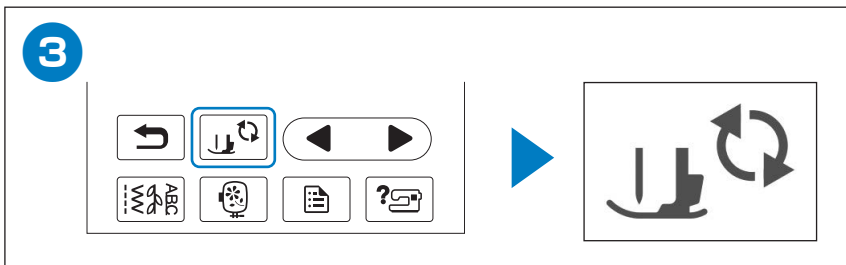
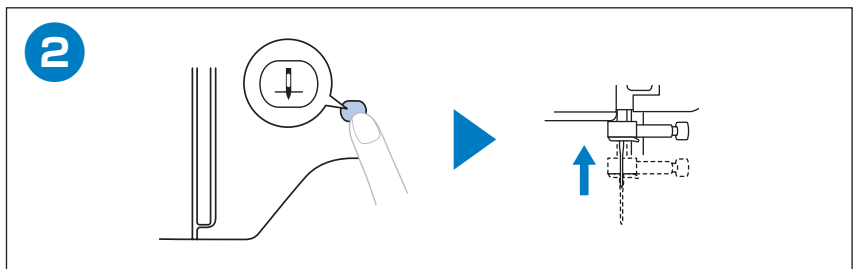
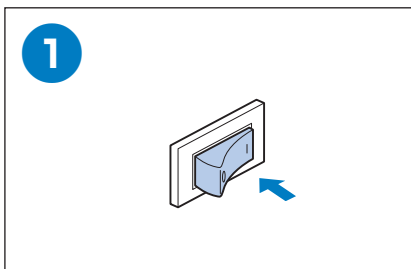
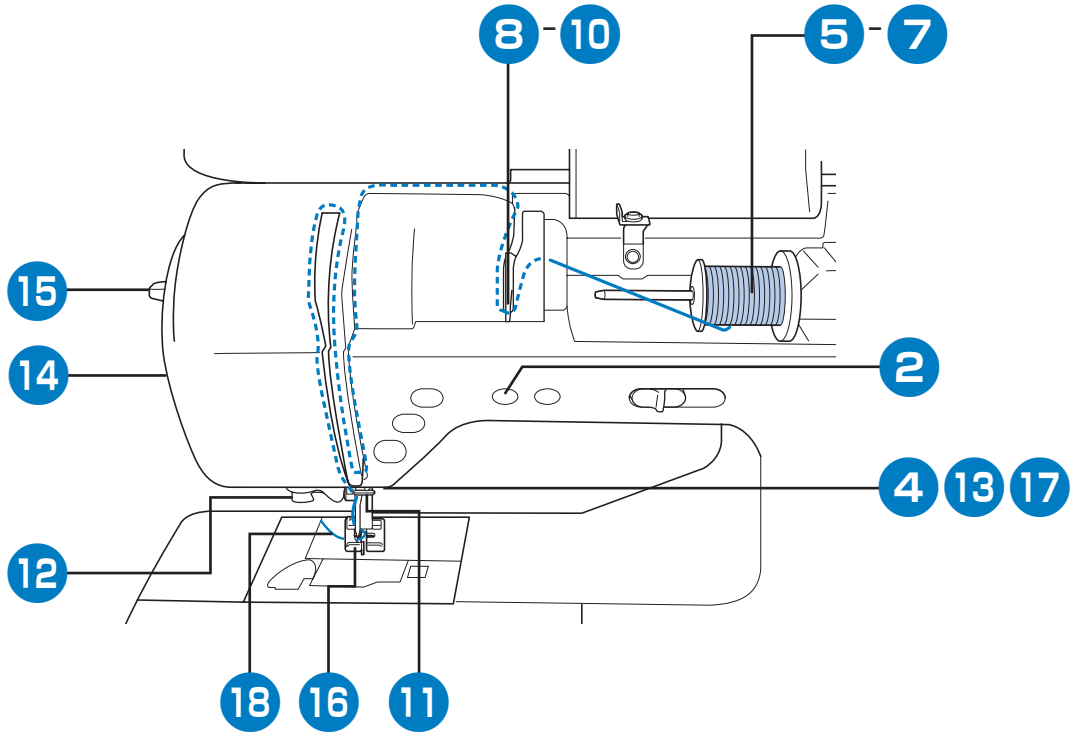

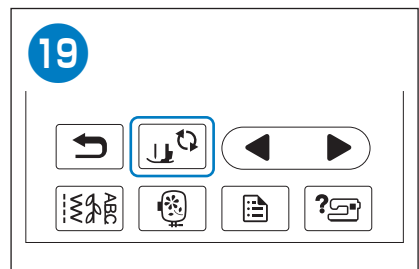
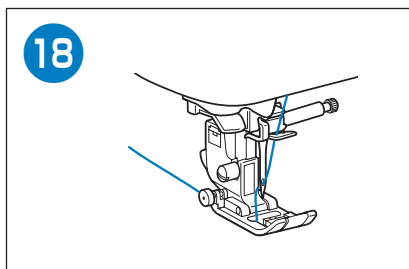
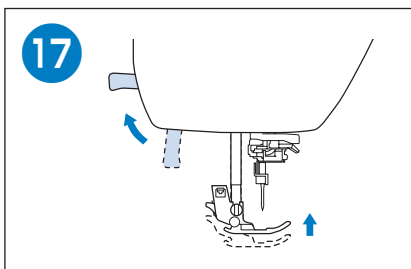
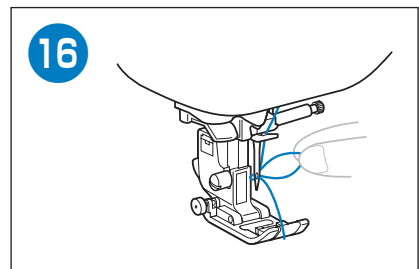
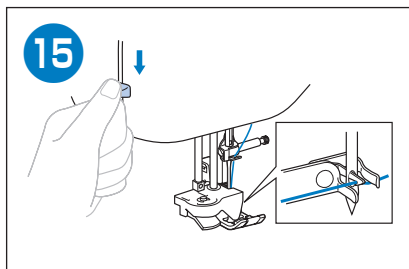
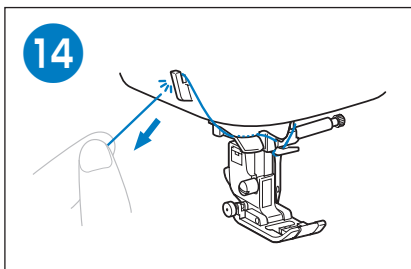
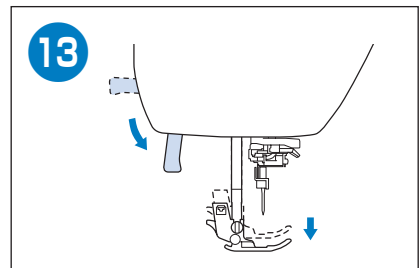
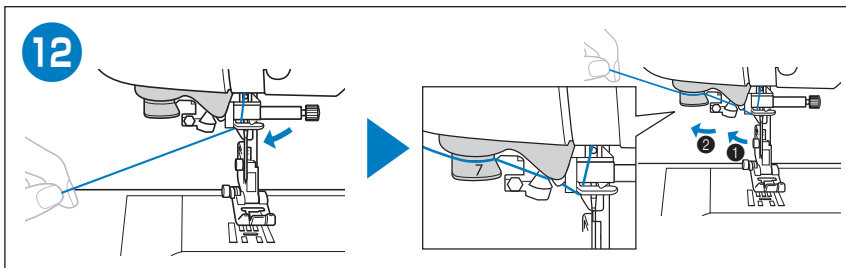
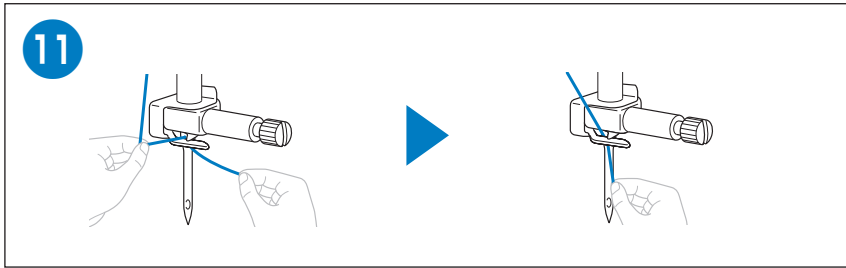
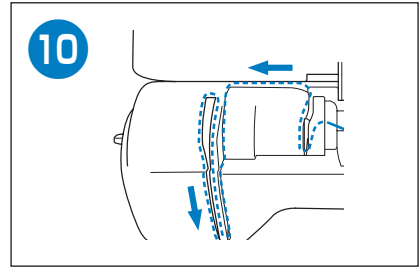
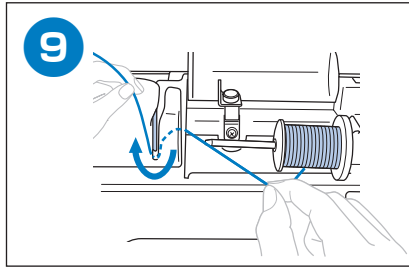
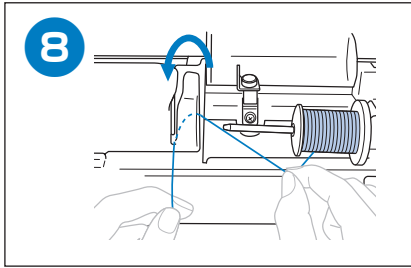

Selecting and Sewing Stitches

Velge og sy sting
 Välja och sy stygn
 Valg og syning af sømme
 Ompeleiden valinta ja ompelu
 Volba a šití stehů
 Öltések kiválasztása és varrás
 Wybieranie i wykonywanie ściegów
 Selectarea și coaserea cusăturilor
 Dūrienu atlasīšana un šūšana

◆ Utility Stitches
◆ Užitkové stehy

◆ Nyttesøm
◆ Haszonöltések

◆ Nyttosömmar
◆ Ściegi użytkowe

◆ Nyttesømme
◆ Cusături utilitare

◆ Hytöyompeleet
◆ Pamatdūrieni

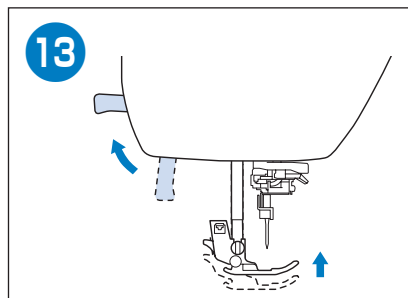
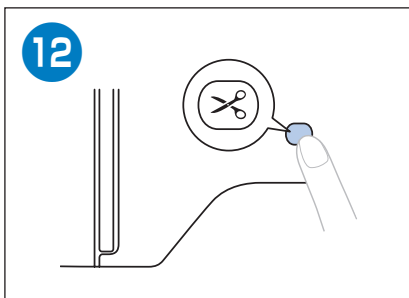
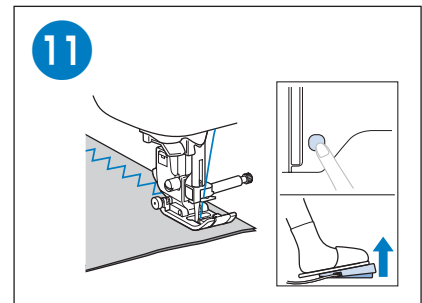
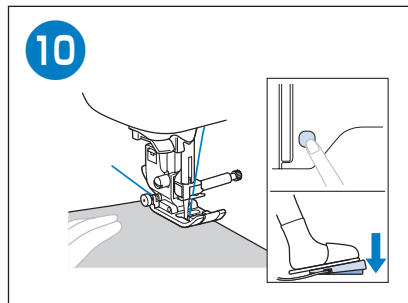
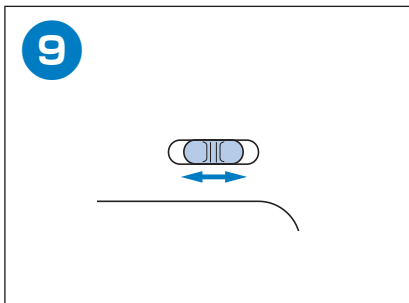
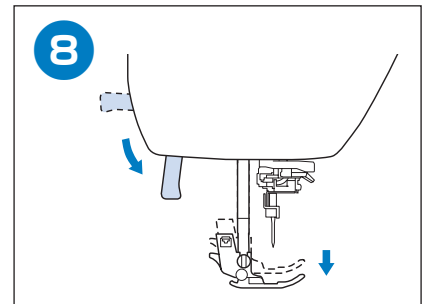
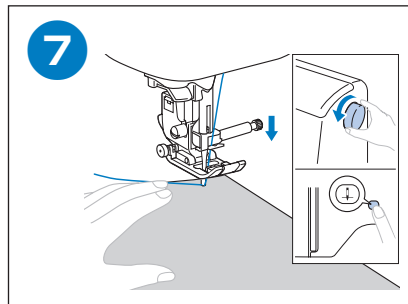
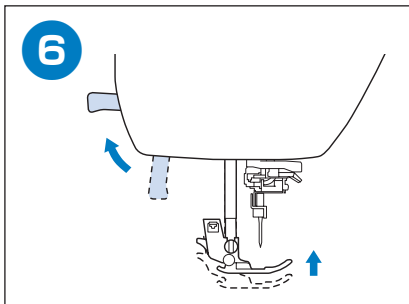
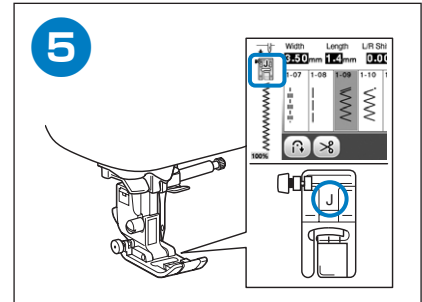
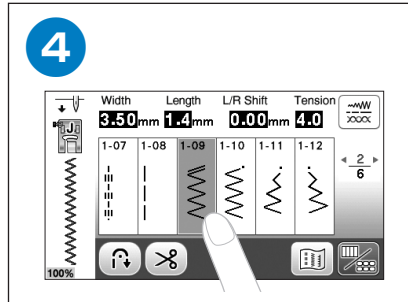
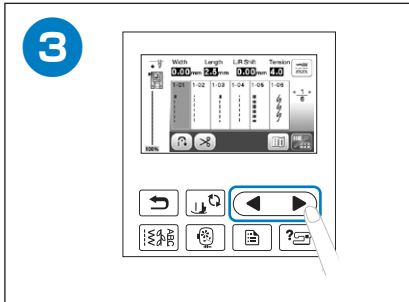
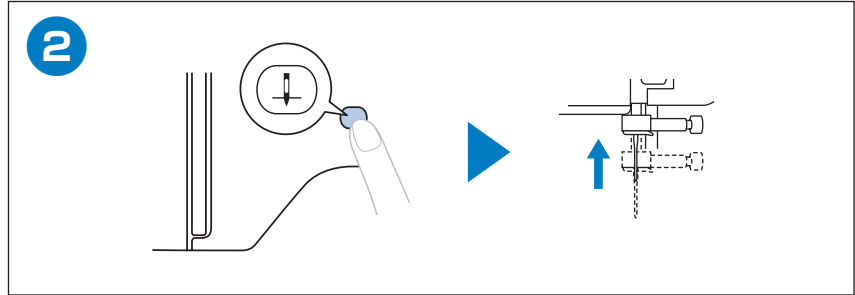
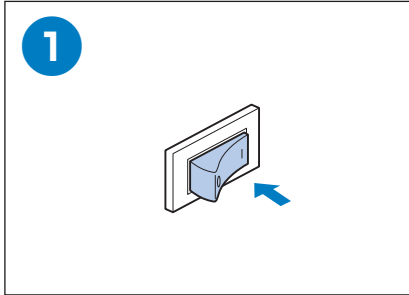

- ◆ Decorative Stitches
- ◆ Prydsøm
- ◆ Dekorativa sömmar
- ◆ Pyntesømme
- ◆ Koristeompeleet
- ◆ Dekoratívni stehy
- ◆ Díszítőöltések
- ◆ Ścięgi dekoracyjne
- ◆ Cusături decorative
- ◆ Dekoratívne durieni

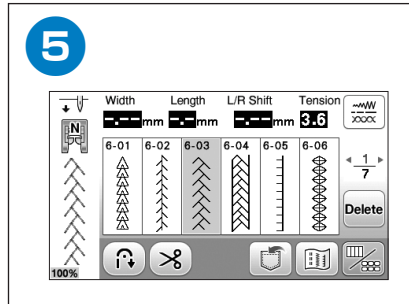
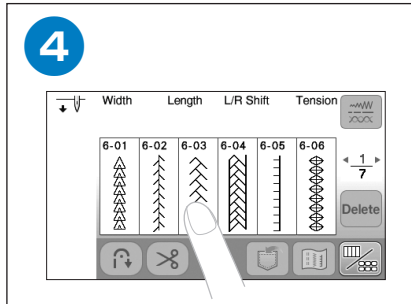
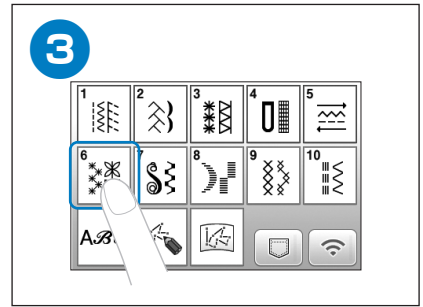
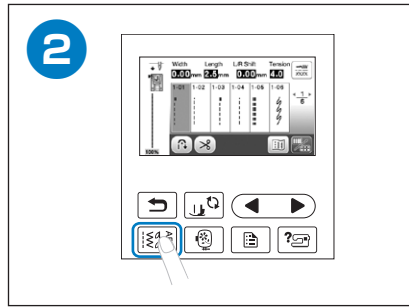
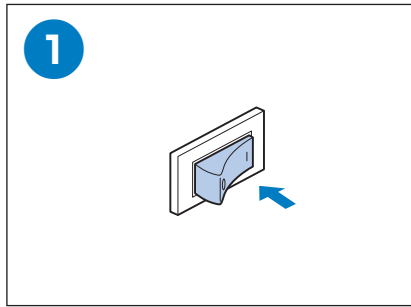

- ◆ Character stitches
- ◆ Tegnsøm
- ◆ Monogramsömmar
- ◆ Alfabet
- ◆ Kirjainmerkkiompeleet
- ◆ Znakové stehy
- ◆ Karakteröltések
- ◆ Ścięgi literowe
- ◆ Cusături caractere
- ◆ Įpašie durieni

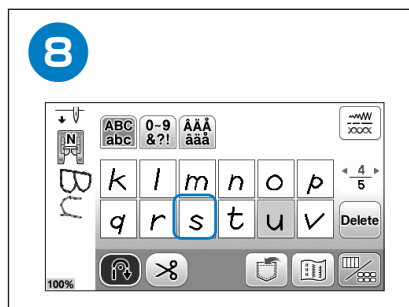
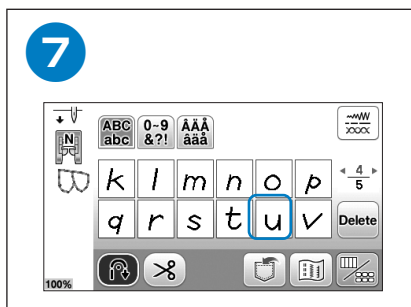
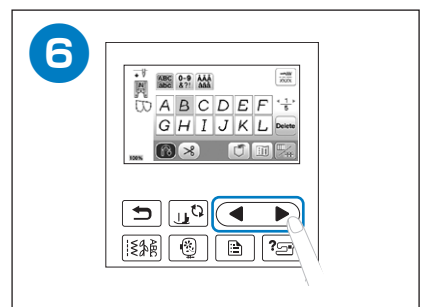
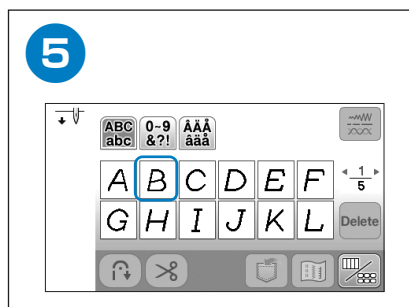
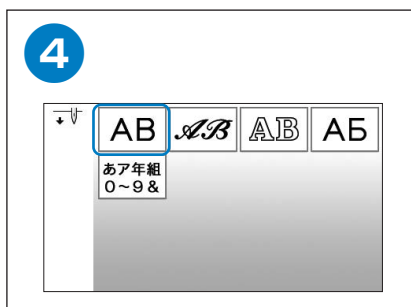
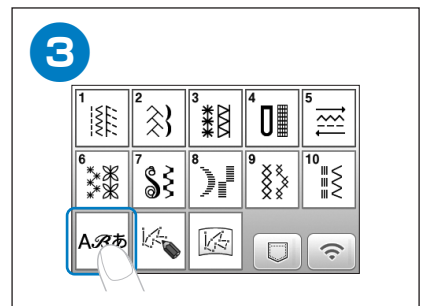
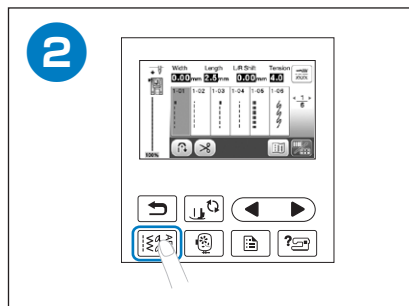
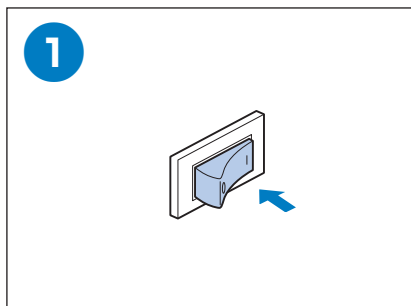



Summary of Stitch Patterns
 Sammendrag av sømmønstre
 Översikt över sömmar
 Søm oversigt
 Yhteenveto ompeleista
 Souhrn vzorů stehů
 Az öltésminták összefoglalása
 Podsumowanie wzorów ściegów
 Modele de cusături
 Kopsavilkums par dūrienu šabloniem

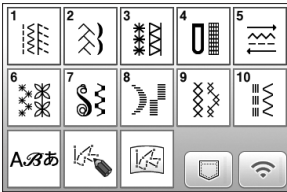

- ◆ Utility Stitches
- ◆ Nyttesøm
- ◆ Nyttosømmar
- ◆ Nyttesømme
- ◆ Hyötyompeleet
- ◆ Užtkové stehy
- ◆ Haszonöltések
- ◆ Ściegi użytkowe
- ◆ Cusături utilitare
- ◆ Pamatdūrieni

• 1-01~1-35

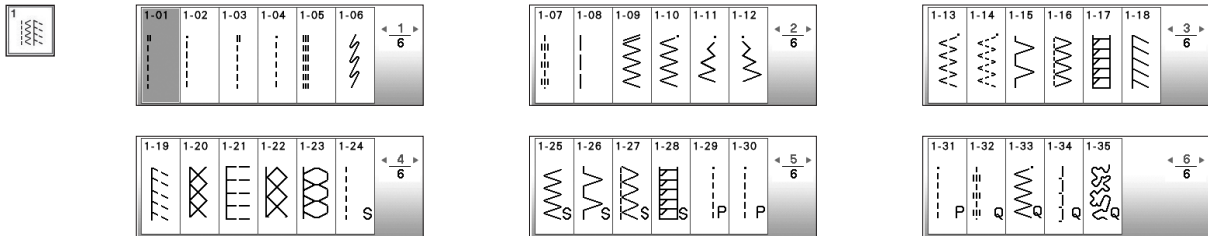

• 2-01~2-20

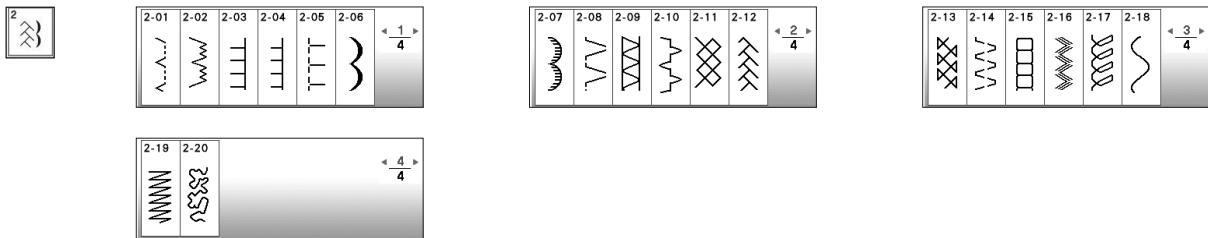

• 3-01~3-22

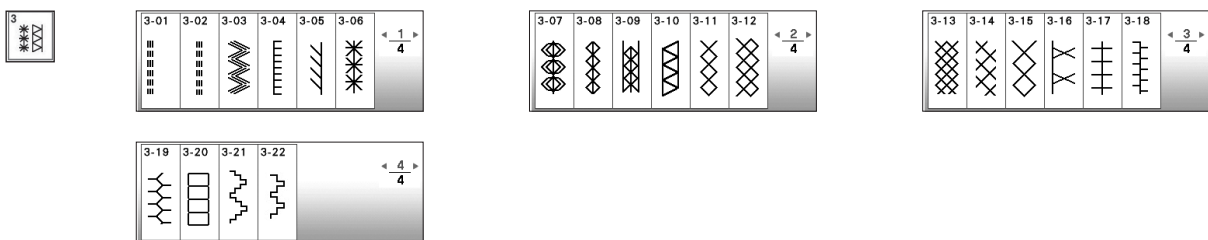

• 4-01~4-15

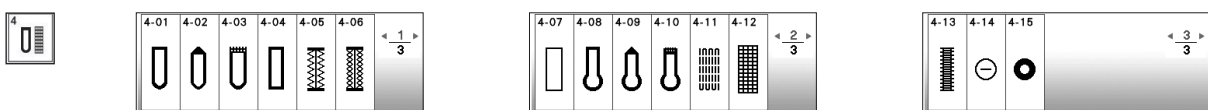

• 5-01~5-08

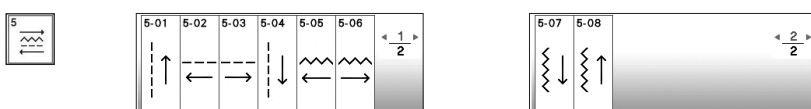

• 6-01~6-40

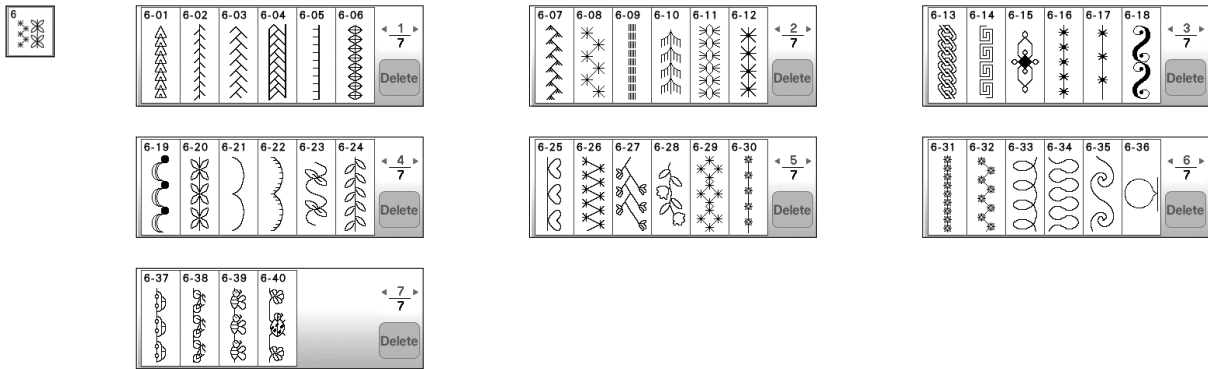

• 7-01~7-12

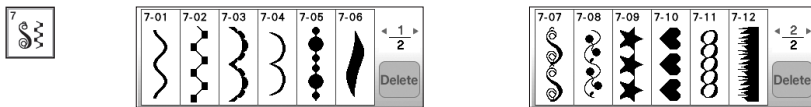

• 8-01~8-17

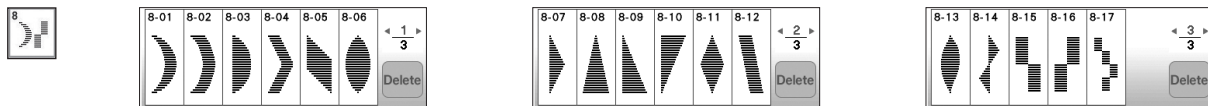

• 9-01~9-14

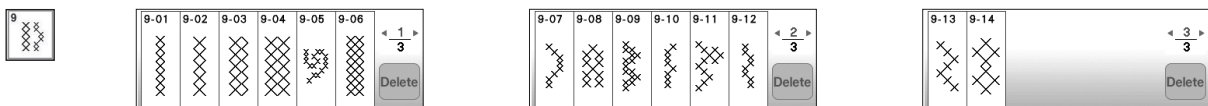

• 10-01~10-58

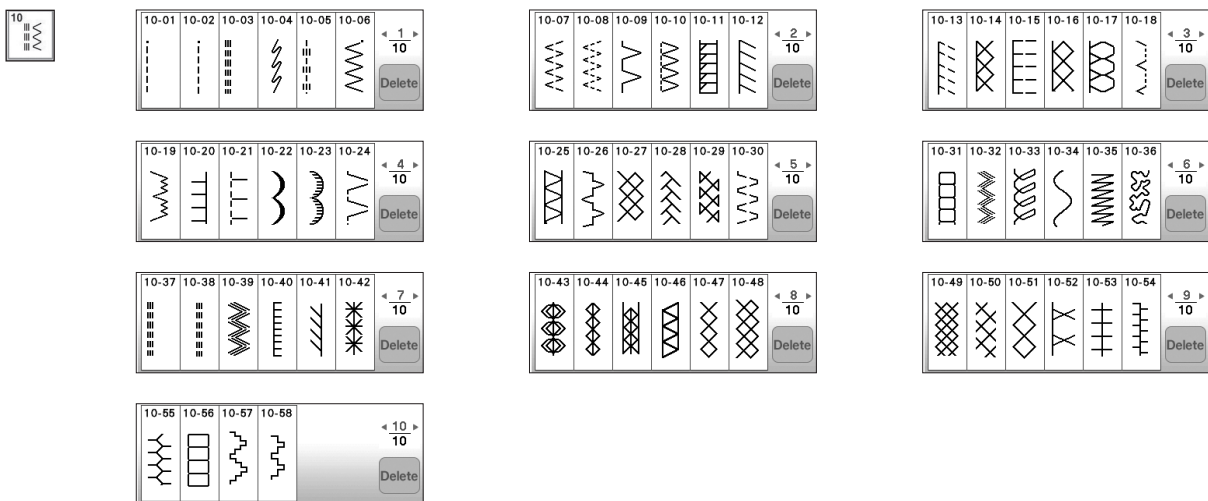

- ◆ Character stitches**
- ◆ Tegnsøm**
- ◆ Monogramsömmar**
- ◆ Alfabet**
- ◆ Kirjainmerkkiompeleet**
- ◆ Znakové stehy**
- ◆ Karakteröltések**
- ◆ Ściegi literowe**
- ◆ Cusături caractere**
- ◆ Įpašie dūrieni**

A: B a b ▶ AB

ABC 0-9 AAA
abc &?! áää

A	B	C	D	E	F
G	H	I	J	K	L

← 1/5 → Delete

ABC 0-9 AAA
abc &?! áää

M	N	O	P	Q	R
S	T	U	V	W	X

← 2/5 → Delete

ABC 0-9 AAA
abc &?! áää

Y	Z	α	b	c	d
e	f	g	h	i	j

← 3/5 → Delete

ABC 0-9 AAA
abc &?! áää

k	l	m	n	o	p
q	r	s	t	u	v

← 4/5 → Delete

ABC 0-9 AAA
abc &?! áää

w	x	y	z	_	
---	---	---	---	---	--

← 5/5 → Delete

ABC 0-9 AAA
abc &?! áää

0	1	2	3	4	5
6	7	8	9	#	%

← 1/5 → Delete

ABC 0-9 AAA
abc &?! áää

\$	£	€	¥	-	+
×	÷	=	*	.	,

← 2/5 → Delete

ABC 0-9 AAA
abc &?! áää

&	?	!	@	<	>
()	[]	/	\

← 3/5 → Delete

ABC 0-9 AAA
abc &?! áää

~	:	;	©	®	™
“	”	”	'	‘	’

← 4/5 → Delete

ABC 0-9 AAA
abc &?! áää

_					
---	--	--	--	--	--

← 5/5 → Delete

ABC 0-9 AAA
abc &?! áää

À	Ä	Á	Æ	à	á
â	ã	ä	å	æ	ç

← 1/5 → Delete

ABC 0-9 AAA
abc &?! áää

ç	Ð	È	É	Ê	Ë
è	é	ê	ë	Í	Ï

← 2/5 → Delete

ABC 0-9 AAA
abc &?! áää

Ì	í	î	ï	Ñ	
Ñ	ñ	Ò	Ö	Ø	Õ

← 3/5 → Delete

ABC 0-9 AAA
abc &?! áää

Œ	ò	ó	ô	ö	ø
ó	œ	ƒ	ƒ	Û	Û

← 4/5 → Delete

ABC 0-9 AAA
abc &?! áää

ù	ú	û	ü	z	ƒ
ƒ	ƒ	_			

← 5/5 → Delete

A: B a b ▶ AB

ABC 0-9 AAA
abc &?! áää

A	B	C	D	E	F
G	H	I	J	K	L

← 1/5 → Delete

ABC 0-9 AAA
abc &?! áää

M	N	O	P	Q	R
S	T	U	V	W	X

← 2/5 → Delete

ABC 0-9 AAA
abc &?! áää

Y	Z	α	b	c	d
e	f	g	h	i	j

← 3/5 → Delete

ABC 0-9 AAA
abc &?! áää

k	l	m	n	o	p
q	r	s	t	u	v

← 4/5 → Delete

ABC 0-9 AAA
abc &?! áää

w	x	y	z	_	
---	---	---	---	---	--

← 5/5 → Delete

ABC 0-9 AAA
abc &?! áää

0	1	2	3	4	5
6	7	8	9	#	%

← 1/5 → Delete

ABC 0-9 AAA
abc &?! áää

\$	£	€	¥	-	+
×	÷	=	*	.	,

← 2/5 → Delete

ABC 0-9 AAA
abc &?! áää

&	?	!	@	<	>
()	[]	/	\

← 3/5 → Delete

ABC 0-9 AAA
abc &?! áää

~	:	;	©	®	™
“	”	”	'	‘	’

← 4/5 → Delete

ABC 0-9 AAA
abc &?! áää

_					
---	--	--	--	--	--

← 5/5 → Delete

ABC 0-9 AAA
abc &?! áää

À	Ä	Á	Æ	à	á
â	ã	ä	å	æ	ç

← 1/5 → Delete

ABC 0-9 AAA
abc &?! áää

ç	Ð	È	É	Ê	Ë
è	é	ê	ë	Í	Ï

← 2/5 → Delete

ABC 0-9 AAA
abc &?! áää

Ì	í	î	ï	Ñ	
Ñ	ñ	Ò	Ö	Ø	Õ

← 3/5 → Delete

ABC 0-9 AAA
abc &?! áää

Œ	ò	ó	ô	ö	ø
ó	œ	ƒ	ƒ	Û	Û

← 4/5 → Delete

ABC 0-9 AAA
abc &?! áää

ù	ú	û	ü	z	ƒ
ƒ	ƒ	_			

← 5/5 → Delete

A.3.3 AB

ABC abc	0-9 &?! aaa	AAA aaa	~NW ~W			
A	B	C	D	E	F	← 1/5 →
G	H	I	J	K	L	Delete

ABC abc	0-9 &?! aaa	AAA aaa	~NW ~W			
M	N	O	P	Q	R	← 2/5 →
S	T	U	V	W	X	Delete

ABC abc	0-9 &?! aaa	AAA aaa	~NW ~W			
Y	Z	a	b	c	d	← 3/5 →
e	f	g	h	i	j	Delete

ABC abc	0-9 &?! aaa	AAA aaa	~NW ~W			
k	l	m	n	o	p	← 4/5 →
q	r	s	t	u	v	Delete

ABC abc	0-9 &?! aaa	AAA aaa	~NW ~W		
w	x	y	z	_	← 5/5 →
Delete					

ABC abc	0-9 &?! aaa	AAA aaa	~NW ~W			
0	1	2	3	4	5	← 1/5 →
6	7	8	9	#	%	Delete

ABC abc	0-9 &?! aaa	AAA aaa	~NW ~W			
§	€	¢	¥	¤	+	← 2/5 →
×	÷	≡	✳	°	,	Delete

ABC abc	0-9 &?! aaa	AAA aaa	~NW ~W			
&	?	!	⊙	<	>	← 3/5 →
()	[]	/	\	Delete

ABC abc	0-9 &?! aaa	AAA aaa	~NW ~W			
~	°	°	⊙	⊙	™	← 4/5 →
σ	ρ	π	ν	δ	ρ	Delete

ABC abc	0-9 &?! aaa	AAA aaa	~NW ~W			
_						← 5/5 →
Delete						

ABC abc	0-9 &?! aaa	AAA aaa	~NW ~W			
Â	Ä	Å	Æ	à	á	← 1/5 →
â	ä	å	æ	ç		Delete

ABC abc	0-9 &?! aaa	AAA aaa	~NW ~W			
Ç	Ð	È	É	Ê	Ë	← 2/5 →
È	É	Ê	Ë	Ì	Í	Delete

ABC abc	0-9 &?! aaa	AAA aaa	~NW ~W			
İ	ı	í	ï	ı	Ñ	← 3/5 →
Ñ	ñ	Ö	ö	Ø	Ó	Delete

ABC abc	0-9 &?! aaa	AAA aaa	~NW ~W			
œ	ò	ó	ô	õ	ø	← 4/5 →
ó	œ	ř	ť	Ů	ů	Delete

ABC abc	0-9 &?! aaa	AAA aaa	~NW ~W			
Ù	ú	û	ü	ž	Ɔ	← 5/5 →
Ɔ	ß	_				Delete

A.3.3 AB

АВВ	абв	0-9 &?! aaa	~NW ~W			
А	Б	В	Г	Д	Е	← 1/4 →
Ё	Ж	З	И	Й	К	Delete

АВВ	абв	0-9 &?! aaa	~NW ~W			
Л	М	Н	О	П	Р	← 2/4 →
С	Т	У	Ф	Х	Ц	Delete

АВВ	абв	0-9 &?! aaa	~NW ~W			
Ч	Ш	Щ	Ъ	Ы	Ь	← 3/4 →
Э	Ю	Я	Г	Е	І	Delete

АВВ	абв	0-9 &?! aaa	~NW ~W			
İ	ı	ñ	ñ	Ј	Ј	← 4/4 →
Ь	Ц	Ѓ	Ѕ	Ќ	_	Delete

АВВ	абв	0-9 &?! aaa	~NW ~W			
а	б	в	г	д	е	← 1/4 →
ё	ж	з	и	й	к	Delete

АВВ	абв	0-9 &?! aaa	~NW ~W			
Л	М	Н	О	П	Р	← 2/4 →
С	Т	У	Ф	Х	Ц	Delete

АВВ	абв	0-9 &?! aaa	~NW ~W			
ч	ш	щ	ъ	ы	ь	← 3/4 →
э	ю	я	г	е	і	Delete

АВВ	абв	0-9 &?! aaa	~NW ~W			
ı	ı	ñ	ñ	Ј	Ј	← 4/4 →
Ь	Ц	Ѓ	Ѕ	Ќ	_	Delete

АВВ	абв	0-9 &?! aaa	~NW ~W			
0	1	2	3	4	5	← 1/2 →
6	7	8	9	-	.	Delete

АВВ	абв	0-9 &?! aaa	~NW ~W			
,	&	?	!	()	← 2/2 →
/	'	_	Delete			

Katakana characters: One of the Japanese character sets.
 Katakana-tegn: et av de japanske tegnssettene.
 Katakana-tecken: en japansk teckenuppsättning.
 Katakana-tegn: et japansk alfabet.
 Katakana-merkit: yksi japanin merkistöistä.
 Znaký písma katakana: jedna ze sad japonských znaků.
 Katakana karakter: A japán karakterkészlet egy eleme.
 Znaki Katakana: jeden z japońskich zestawów znaków.
 Caractere Katakana: Unul din seturile de caractere japoneze.
 Katakana rakstzīmes: viena no japāņu rakstzīmju grupām.

Hiragana characters: One of the Japanese character sets.
 Hiragana-tegn: et av de japanske tegnssettene.
 Hiragana-tecken: en japansk teckenuppsättning.
 Hiragana-tegn: et japansk alfabet.
 Hiragana-merkit: yksi japanin merkistöistä.
 Znaký písma hiragana: jedna ze sad japonských znaků.
 Hiragana karakter: A japán karakterkészlet egy eleme.
 Znaki Hiragana: jeden z japońskich zestawów znaków.
 Caractere Hiragana: Unul din seturile de caractere japoneze.
 Hirigana rakstzīmes: viena no japāņu rakstzīmju grupām.

Arabic numerals, Japanese Kanji numerals
 Arabiske tall, japanske kanji-tall
 Arabiska siffror, japanska Kanji-siffror
 Arabiske tal, japanske Kanji-tal
 Arabialaiset numerot, japanilaiset kanji-numerot
 Arabské číslice, japonské číslice kandži
 Arab számok, japán kandzsi számok
 Cyfry arabskie, japońskie cyfry Kanji
 Numerale arabe, numerale japoneze Kanji
 Arābu cipari, japāņu kanji cipari

Kanji characters: Often used in daily life / symbols.
 Kanji-tegn: brukes ofte til daglig/symboler.
 Kanji-tecken: används ofta för dagligt bruk/symboler.
 Kanji-tegn: bruges ofte i hverdagen/symboler.
 Kanji-merkit: käytetään usein arkielämässä / symboleissa.
 Znaký kandži: často používané v každodenním životě / symboly.
 Kandzsi karakter: A mindennapi életben / szimbólumként gyakran használt karakter.
 Znaki Kanji: często używane w życiu codziennym i symbolach.
 Caractere Kanji: Utilizate adesea în viața de zi cu zi / ca simboluri.
 Kanji rakstzīmes: bieži izmanto sadzīvē/simbolos.



Horizontal
 Horizontal
 Vågrät
 Vandret
 Vaakasuuuntainen
 Horizontálně
 Horizontális
 Poziome
 Orizontale
 Horizontáli

Vertical
 Vertikal
 Lodrät
 Lodret
 Pystysuuntainen
 Vertikálně
 Vertikális
 Pionowe
 Verticale
 Vertikáli

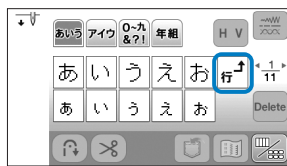

あ行



か行

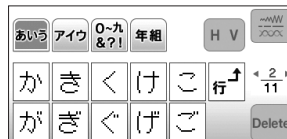

さ行

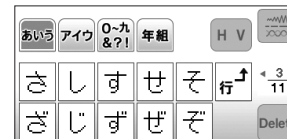

た行

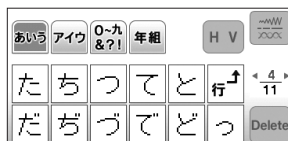

な行

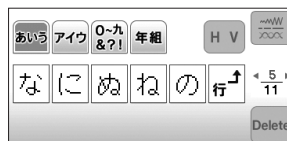

は行



ま行



や行



ら行



わ行



あいう アイウ 0-9 &?! 年組 H V ~nw ~sw

ア	カ	サ	タ	ナ
ハ	マ	ヤ	ラ	ワ

Delete

ア行

あいう アイウ 0-9 &?! 年組 H V ~nw ~sw

ア	イ	ウ	エ	オ	行
ア	イ	ウ	エ	オ	ヴ

Delete

ア行

あいう アイウ 0-9 &?! 年組 H V ~nw ~sw

ア	イ	ウ	エ	オ	行
ア	イ	ウ	エ	オ	ヴ

Delete

カ行

あいう アイウ 0-9 &?! 年組 H V ~nw ~sw

カ	キ	ク	ケ	コ	行
ガ	ギ	グ	ゲ	ゴ	

Delete

サ行

あいう アイウ 0-9 &?! 年組 H V ~nw ~sw

サ	シ	ス	セ	ソ	行
ザ	ジ	ズ	ゼ	ゾ	

Delete

タ行

あいう アイウ 0-9 &?! 年組 H V ~nw ~sw

タ	チ	ツ	テ	ト	行
ダ	ヂ	ヅ	デ	ド	ッ

Delete

ナ行

あいう アイウ 0-9 &?! 年組 H V ~nw ~sw

ナ	ニ	ヌ	ネ	ノ	行

Delete

ハ行

あいう アイウ 0-9 &?! 年組 H V ~nw ~sw

ハ	ヒ	フ	ヘ	ホ	行
バ	ビ	ブ	ベ	ボ	

Delete

あいう アイウ 0-9 &?! 年組 H V ~nw ~sw

パ	ピ	プ	ペ	ポ	行

Delete

マ行

あいう アイウ 0-9 &?! 年組 H V ~nw ~sw

マ	ミ	ム	メ	モ	行

Delete

ヤ行

あいう アイウ 0-9 &?! 年組 H V ~nw ~sw

ヤ	ユ	ヨ			行
ヤ	ユ	ヨ			

Delete

ラ行

あいう アイウ 0-9 &?! 年組 H V ~nw ~sw

ラ	リ	ル	レ	ロ	行

Delete

ワ行

あいう アイウ 0-9 &?! 年組 H V ~nw ~sw

ワ	ヲ	ン	ー		行

Delete

あいう アイウ 0-9 &?! 年組 H V ~nw ~sw

0	1	2	3	4	5	行
6	7	8	9	○	ー	

Delete

あいう アイウ 0-9 &?! 年組 H V ~nw ~sw

二	三	四	五	六	七	行
八	九	十	&	?	!	

Delete

あいう アイウ 0-9 &?! 年組 H V ~nw ~sw

()	-	ー		行

Delete

あいう アイウ 0-9 &?! 年組 H V ~nw ~sw

生	年	月	日	才	保	行
育	幼	稚	園	小	中	

Delete

あいう アイウ 0-9 &?! 年組 H V ~nw ~sw

学	校	組	部	火	水	行
木	金	土	ー			

Delete

- Example of Kanji characters in daily life
- Eksempel på dagligdagse kanji-tegn
- Exempel på Kanji-tecken som används för dagligt bruk
- Eksempel på Kanji-tegn i hverdagen
- Esimerkki kanji-merkeistä arkielämässä
- Příklad znaků kandži v každodenním životě
- Példa a mindennapokban használt kandzsi karakterekre
- Przykłady znaków Kanji w życiu codziennym
- Exemple de caractere Kanji î viața de zi cu zi
- Kandži rakstzīmju lietojuma piemērs ikdienas situācijā

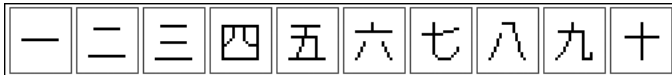

1, 2, 3, 4, 5, 6, 7, 8, 9, 10

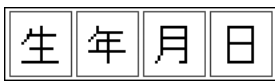

Date of birth	Fødselsdato	Födelsedatum	Fødselsdato	Syntymäaika
Datum narození	Születési idő	Data urodzenia	Data nașterii	Dzimšanas datums

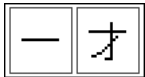

1 year old	1 år gammel	1 år gammal	1 år gammel	1-vuotias
1 rok starý	1 éves	1 rok	1 an	1 gadu vecs



Nursery school	Barnehage	Daghem	Vuggestue	Päiväkoti
Jesle	Bölcsőde	Žłobek	Creșă	Pirmsskolas sagatavošana



Kindergarten	Førscole	Förskola	Børnehave	Lastentarha
Školka	Óvoda	Przedszkole	Grāīniņa	Bērnudārzs



Elementary school	Barneskole	Grundskola	Grundskole	Ala-aste
Základní škola	Általános iskola	Szkola podstawowa	Școală primară	Sākumskola



Junior high school	Ungdomsskole	Högstadiet	7.-9. skoleår	Yläaste
Střední škola	Középiskola	Szkola średnia	Gimnaziu	Pamatskola



Group/Class	Gruppe/klasse	Grupp/klass	Gruppe/klasse	Ryhmä/luokka
Skupina/Třída	Csoport/osztály	Grupa/klasa	Grupă/Clasă	Grupa/klase



Club/Division	Klubb/divisjon	Klubb/division	Klub/division	Yhdistys/jaosto
Klub/Oddíl	Klub/részleg	Klub/oddział	Club/Divizie	Klubs/divīzija



Moon/Monday
Měsíc/Pondělí

Måne/mandag
Hold/hétfő

Måne/Måndag
Księżyc/poniedziałek

Måne/mandag
Lună/Luni

Kuu/maanantai
Mēness/pirmdiena



Fire/Tuesday
Oheň/Úterý

Brann/tirsdag
Tűz/kedd

Eld/Tisdag
Ogień/wtorek

Ild/tirsdag
Foc/Marți

Tuli/tiistai
Uguns/otrdiena



Water/Wednesday
Voda/Středa

Vann/onsdag
Víz/szerda

Vatten/Onsdag
Woda/środa

Vand/onsdag
Apă/Miercuri

Vesi/keskiviikko
Ūdens/trešdiena



Tree/Thursday
Strom/Čtvrtek

Trē/torsdag
Fa/csütörtök

Träd/Torsdag
Drzewo/czwartek

Træ/torsdag
Arbore/Joi

Puu/torstai
Koks/ceturtdiena



Gold/Friday
Zlato/Pátek

Gull/fredag
Arany/péntek

Guld/Fredag
Zloto/piątek

Guld/fredag
Aur/Vineri

Kulta/perjantai
Zelts/piektdiena



Soil/Saturday
Země/Sobota

Jord/lørdag
Föld/szombat

Jord/Lördag
Ziemia/sobota

Jord/lørdag
Pământ/Sâmbătă

Maa/lauantai
Augsne/sestdiena



Sun/Sunday
Slunce/Neděle

Sol/søndag
Nap/vasárnap

Sol/Söndag
Słońce/niedziela

Sol/søndag
Soare/Duminică

Aurinko/sunnuntai
Saule/svētdiena

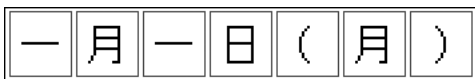

January 1st (Monday)
1. ledna (pondělí)

1. januar (mandag)
Január 1. (hétfő)

1 januari (måndag)
1 stycznia (poniedziałek)

1. januar (mandag)
1 Ianuarie (luni)

1. tammikuuta (maanantai)
1. janvāris (pirmdiena)



Preparing to Embroider
Gjøre seg klar til å brodere
Förbereda brodering
Forberedelse til brodering
Kirjontaan valmistautuminen
Příprava k vyšívání
Előkészítés a hímzéshez
Przygotowanie do haftowania
Pregătirea pentru brodare
Sagatavošanās izšūšanai

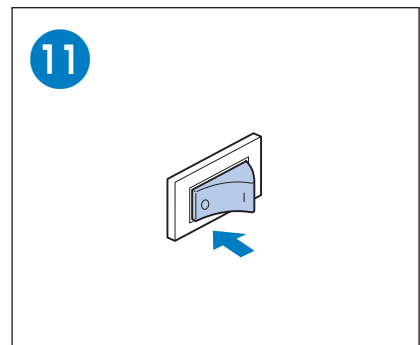
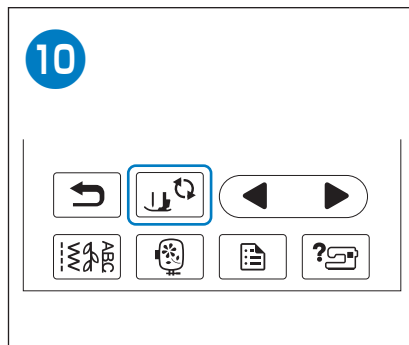
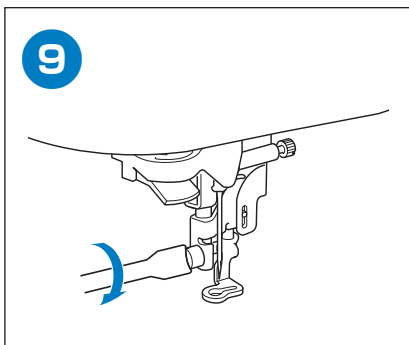
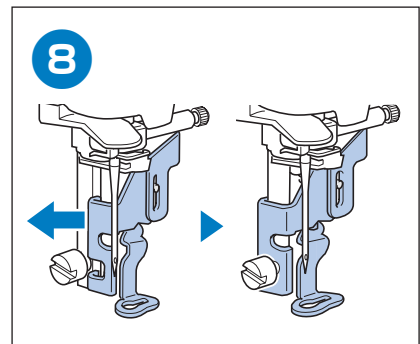
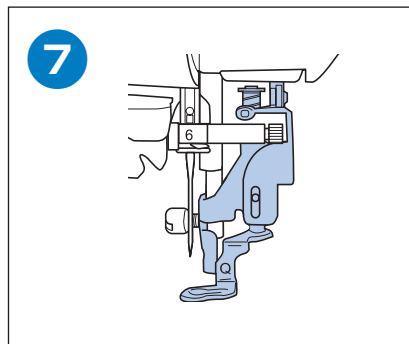
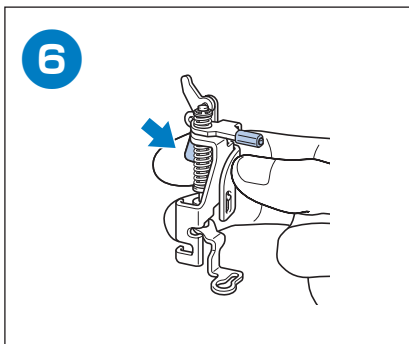
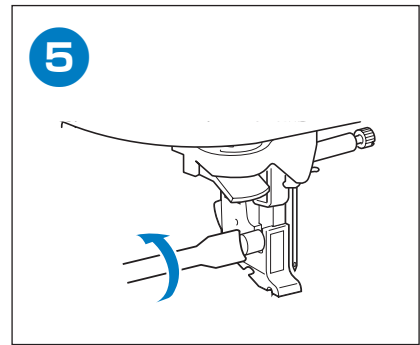
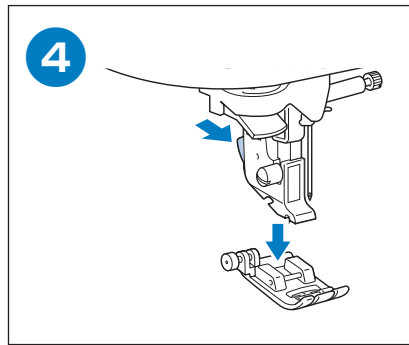
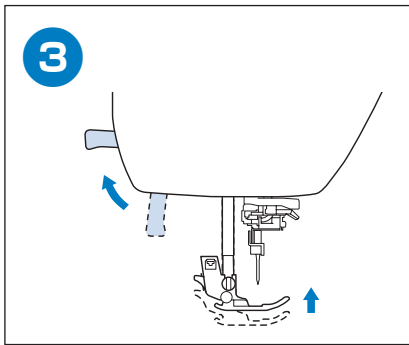
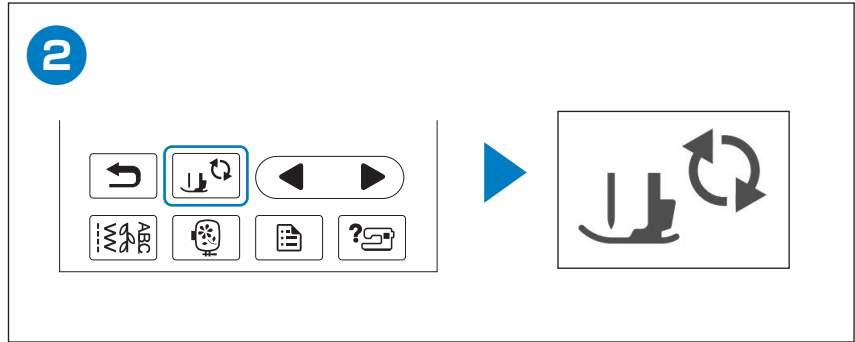
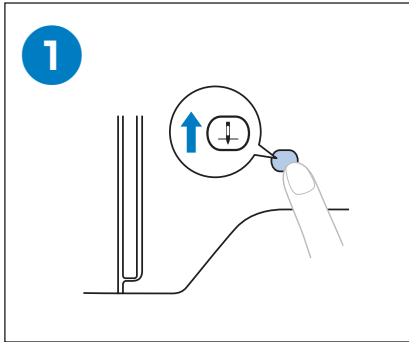

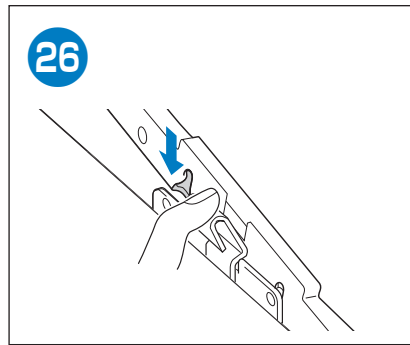
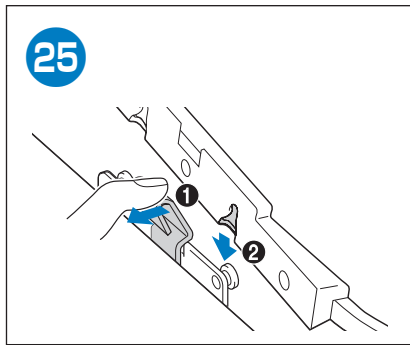
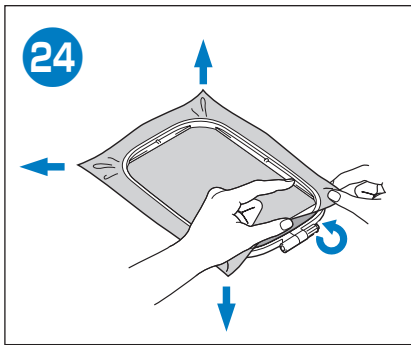
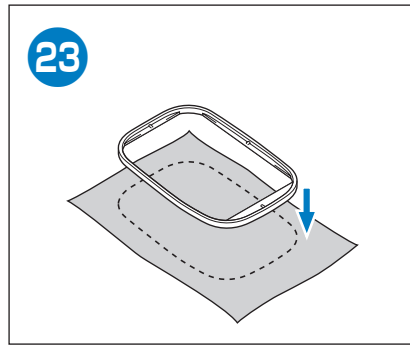
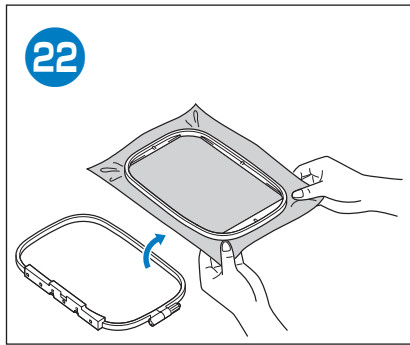
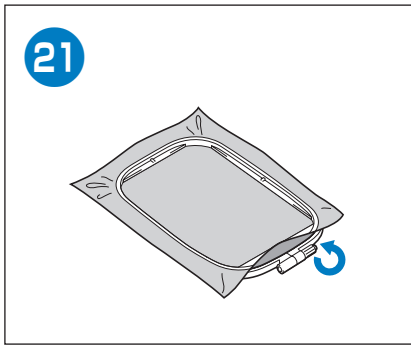
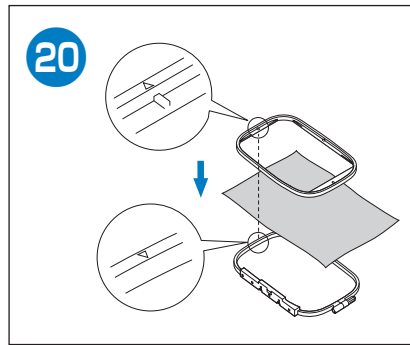
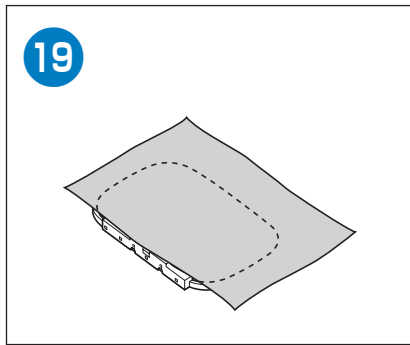
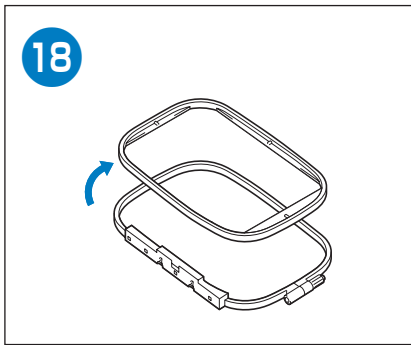
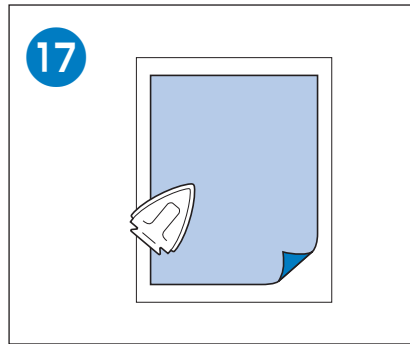
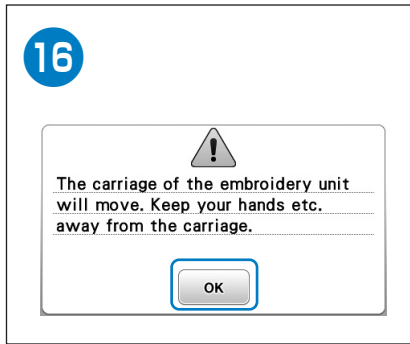
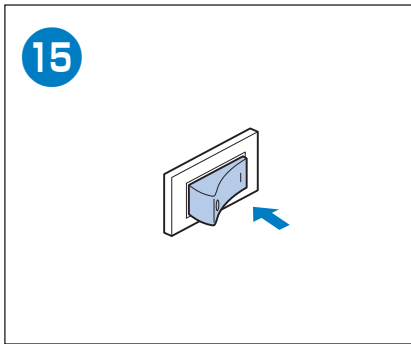
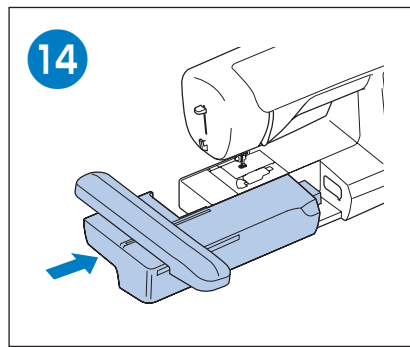
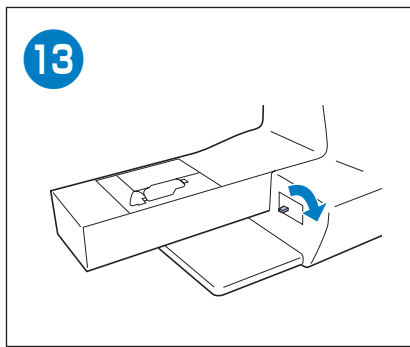
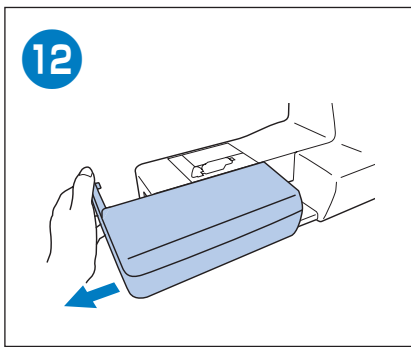



Selecting Embroidery Patterns
Velge broderimønstre
Välja broderimønster
Valg af broderimønstre
Kirjontakuvioiden valinta
Volba vyšívacích vzorů
Hímzsminták kiválasztása
Wybór wzorów haftu
Selectarea modelelor de broderie
Izšūšanas šablonu atlasīšana

